

# General Specifications

## PC-Based Data Acquisition Unit MX100



GS 04M08B01-00E

### Product Overview

The MX100 is a data acquisition unit designed to operate as a front end for PCs. Data measured by the MX100 is transferred to PCs in real-time.

Based on the concept of achieving higher performance and increased ease of use, the MX100 provides the following features:

- High speed/multi-channel/high withstand voltage:
  - Shortest measurement interval of 10 ms (High speed measurement of 24 channels/10 ms or 60 channels/100 ms are enabled. If a single unit consists of MX115-Dxx-H10 modules only, 60 channel/10 ms measurement is possible.)
  - Possible to acquire data of up to 1,200 channels (when software developed by Yokogawa Electric Corporation is used)
  - Reinforced insulation between the input terminal and the case when using the MX110-UNV-H04, MX110-UNV-M10, or MX110-V4R-M06 3700 Vrms (one minute), 600 Vrms/VDC (continuous)

Multi-interval: Mixed use of three types of measurement intervals is enabled within the system (measurement intervals are set for each module).

Flexibility in building a system: A system can be flexibly built or changed between from 4 to 1,200 channels and the measurement intervals of 10 ms-60 s according to module configurations.

- Variety of inputs/outputs:

The following signals can be input/output using combinations of the input/output modules.

  - Types of input  
DCV (DC voltage), TC (thermocouple), 3-wire RTD (resistance temperature detector), 4-wire RTD, DI (non-voltage contact , open collector, level), strain, resistance
  - Types of output  
Contact, DC voltage, DC current, PWM (pulse width modulation)

Adaptability to any type of PC-based measurement environment:  
Software developed by Yokogawa, API, and LabVIEW driver are available.

Easy to setup: PC software developed by Yokogawa strongly supports setting up the network with ease.

No re-wiring between measurements:  
A removable terminal unit is available.

Inclusion of the CF card slot: Measured values are backed up automatically in case of a communication failure.

### Equipment Configuration

MX is designed to enable desired measurement environments in a combination of three elements: main module, input/output module, and base plate. The assembled unit can be utilized for desktop use as it is (modules have legs on their bases). Note that DIN rails are used for the rack mount.

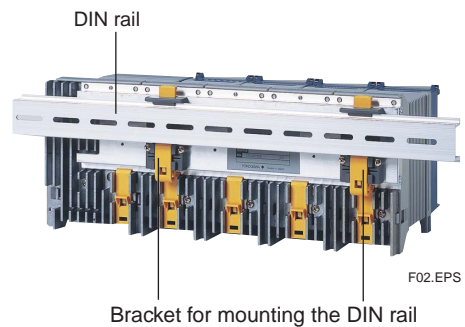
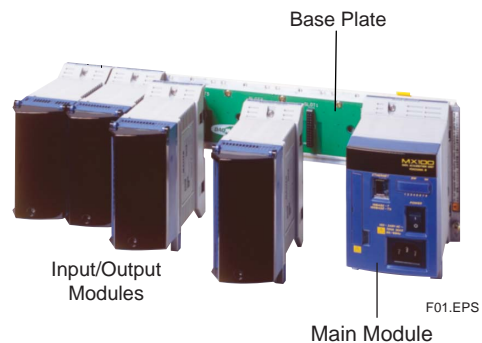

The DIN rail can be easily mounted using the dedicated brackets. Two brackets are provided as standard devices of the base plate (MX150).

**<Main Module> MX100**

The main module is the engine to control data acquisition. It is equipped with a power supply, an Ethernet port, a CompactFlash card slot, etc. One main module has up to six input/output modules. As long as six or less modules are used, the user can choose their types and quantity arbitrarily.

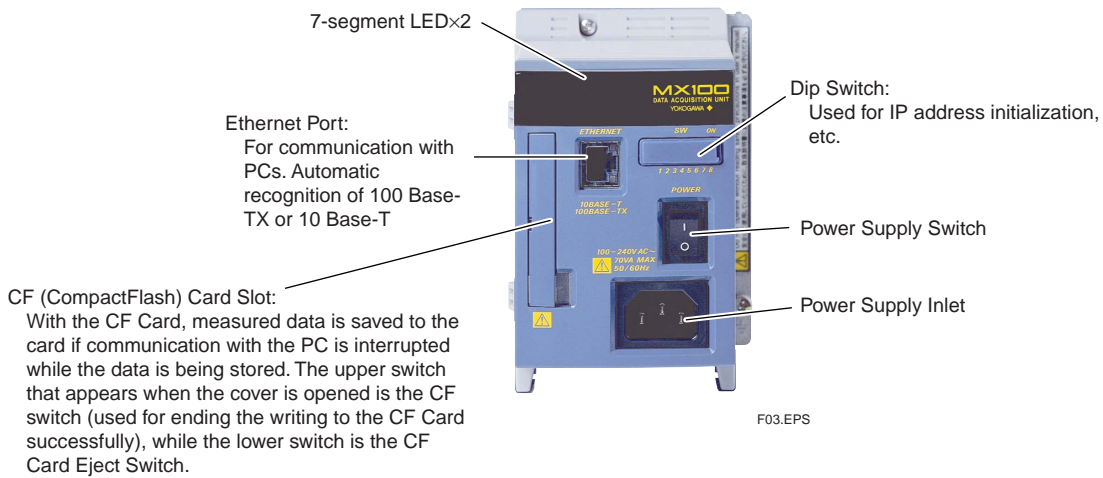

**<Input/Output Module> MX110, MX112, MX115, MX120, MX125**

**• Four-Channel High-Speed Universal Input Module (MX110-UNV-H04)**

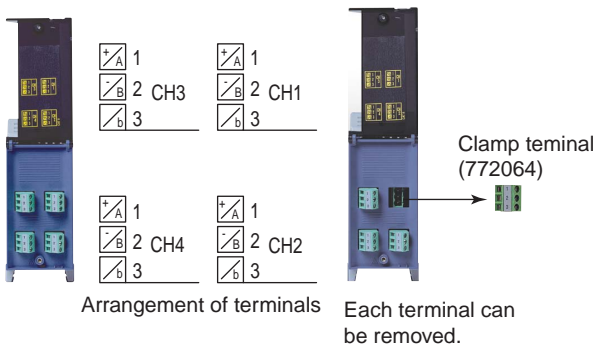

**• Ten-Channel Medium-Speed Universal Input Module (MX110-UNV-M10)**

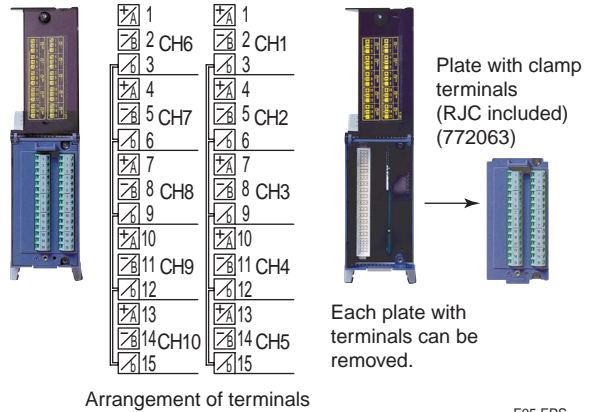

**• Six-Channel Medium-Speed 4-Wire RTD and Resistance Input Module (MX110-V4R-M06)**

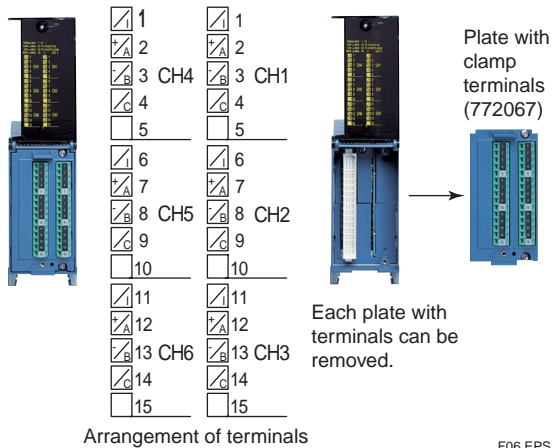

**• Four-Channel Medium-Speed Strain Input Module (built-in bridge resistance of 120 Ω) (MX112-B12-M04)**

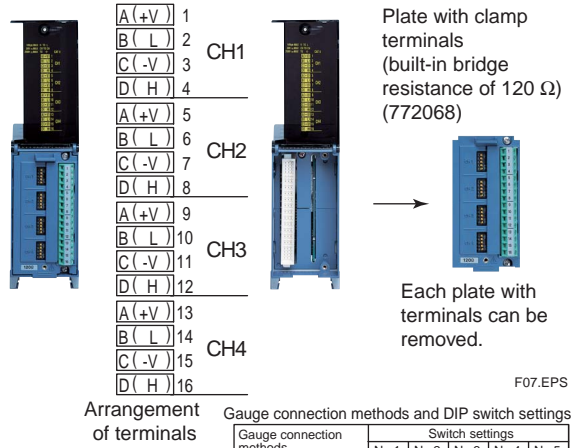

Gauge connection methods and DIP switch settings

Gauge connection methods	Switch settings				
	No.1	No.2	No.3	No.4	No.5
Single-gauge (2-wire)	ON	ON	ON	OFF	OFF
Single-gauge (3-wire)	ON	ON	OFF	ON	OFF
Adjacent-side two-gauge	ON	ON	OFF	OFF	ON
Opposed-side two-gauge	ON	OFF	ON	OFF	ON
Four-gauge	OFF	OFF	OFF	OFF	ON

• **Four-Channel Medium-Speed Strain Input Module (built-in bridge resistance of 350 Ω) (MX112-B35-M04)**

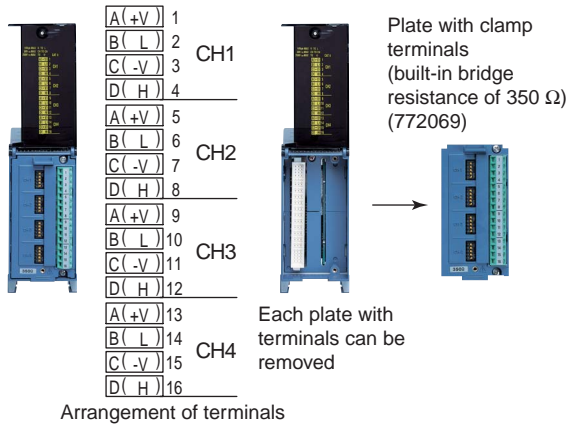

F08.EPS

• **Four-Channel Medium-Speed Strain Input Module (For connection with an external bridge head and strain gauge type sensor, NDIS connector) (MX112-NDI-M04)**

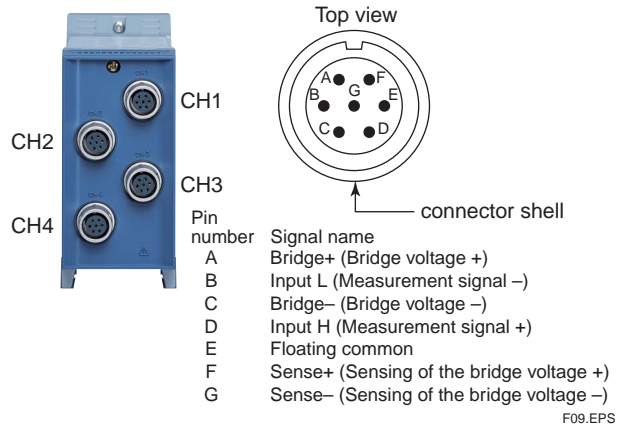

F09.EPS

• **Ten-Channel High-Speed 5 V Digital Input Module (MX115-D05-H10)**

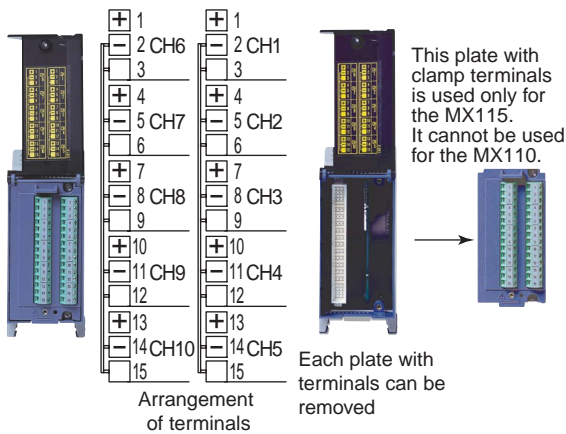

F10.EPS

• **Ten-Channel High-Speed 24 V Digital Input Module (MX115-D24-H10)**

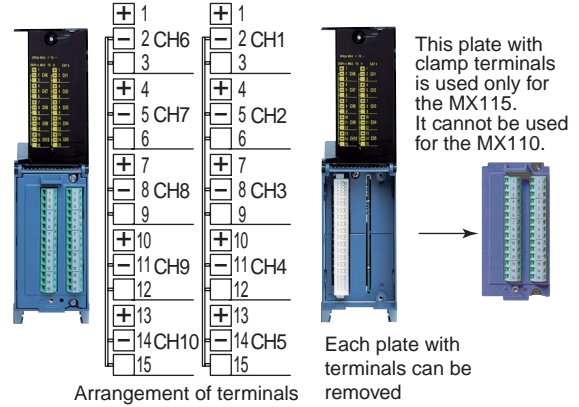

F11.EPS

• **Eight-Channel Medium-Speed Analog Output Module (MX120-VAO-M08)**

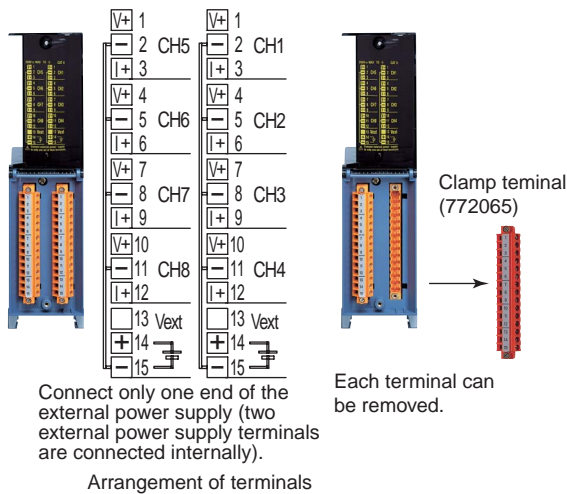

F12.EPS

• **Eight-Channel Medium-Speed PWM Output Module (MX120-PWM-M08)**

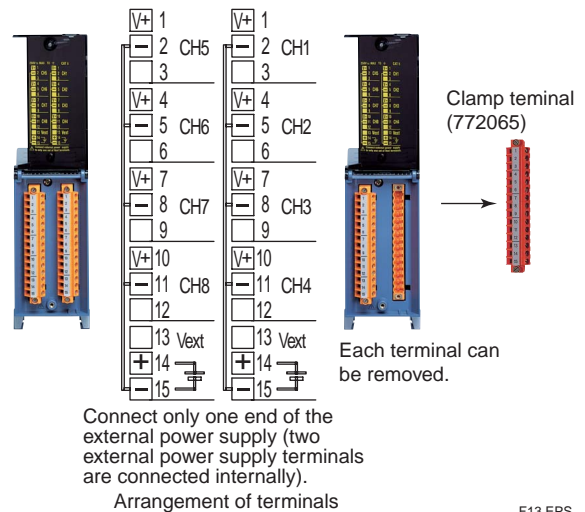

F13.EPS

**• Ten-Channel Medium-Speed Digital Output Module (MX125-MKC-M10)**

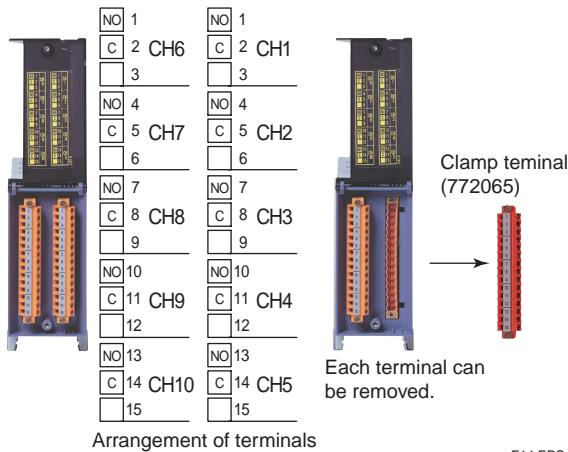

F14.EPS

**<Base Plate> MX150**

The main module and input/output modules are connected using connectors on base plates. The following six types of base plates are available:

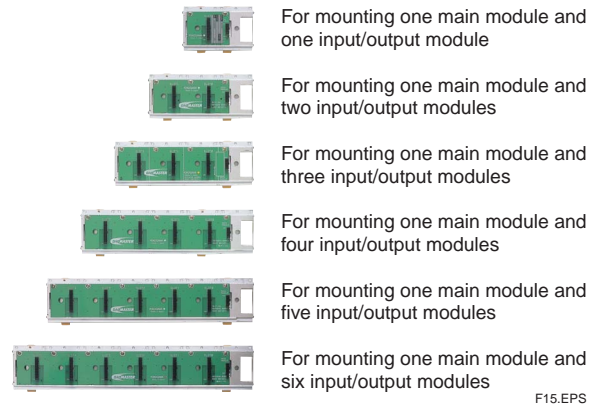

F15.EPS

**<Other Accessories>**

**• Screw terminal plate (M3)**

A screw terminal plate (M3) is available for the Ten-Channel Medium-Speed Universal Input Module (MX110-UNV-M10) and the Ten-Channel High-Speed Digital Input Module (MX115-Dxx-H10). The clamp terminal plate is removed from the MX110-UNV-M10 or MX115-Dxx-H10 and replaced with the screw terminal plate.

You can also specify an option code to order versions of the MX110-UNV-M10 and MX115-Dxx-H10 that are shipped without the clamp terminal plates. If you plan to use only the screw terminal plate and do not need the clamp terminal plate, please specify MX110-UNV-M10/NC or MX115-Dxx-H10/NC when ordering.

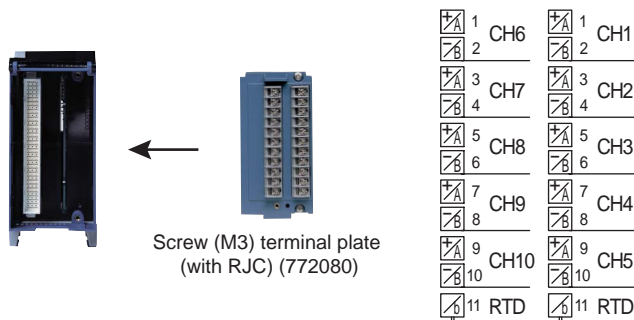

Screw (M3) terminal plate (with RJC) (772080)

Arrangement of terminals

There are two b terminals for three-wire RTD. When connecting 3 or more RTDs, use them in common.

Attach the screw terminal plate (model 772080) in place of the clamp terminal plate.

F15-2.EPS

• **Screw Terminal Block (M4)**

A separate screw terminal block (M4) is available for the Ten-Channel Medium-Speed Universal Input Module (MX110-UNV-M10) and Ten-Channel High-Speed Digital Input Module (MX115-Dxx-H10).

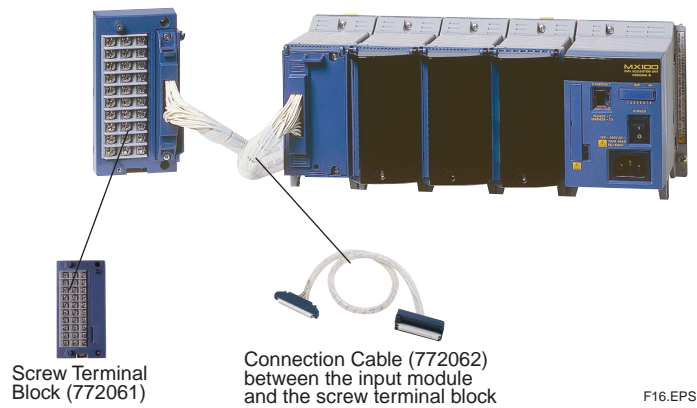

Remove the plate with clamp terminals from the MX110-UNV-M10 or the MX115-Dxx-H10. Then, connect each module with the screw terminal block (772061) by means of the connection cable (772062).

Option code can be added to the MX110-UNV-M10 and the MX115-Dxx-H10 to indicate whether or not the plate with clamp terminals is included at the time of delivery. If the user requires only the screw terminal block and not the clamp terminals, specify either the MX110-UNV-M10/NC or the MX115-D05-H10/NC.

• **Connector Cover for Base Plate**

A connector cover is available for a vacant slot, into which a module is not inserted.



## ■ System Configuration

In order to build an actual measurement system, a personal computer and network devices (such as hubs and cables) are required in addition to the MX. These are to be provided by the user.

### (1) Connection between the PC and a single MX unit

One MX Unit is a combination of a main module, input/output modules, and a base plate. This configuration centers on a single main module.

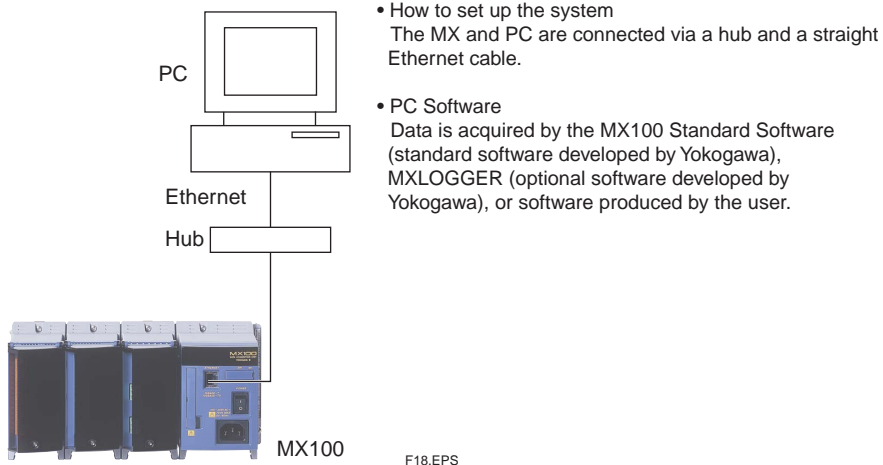

### (2) Connection between the PC and multiple MX units

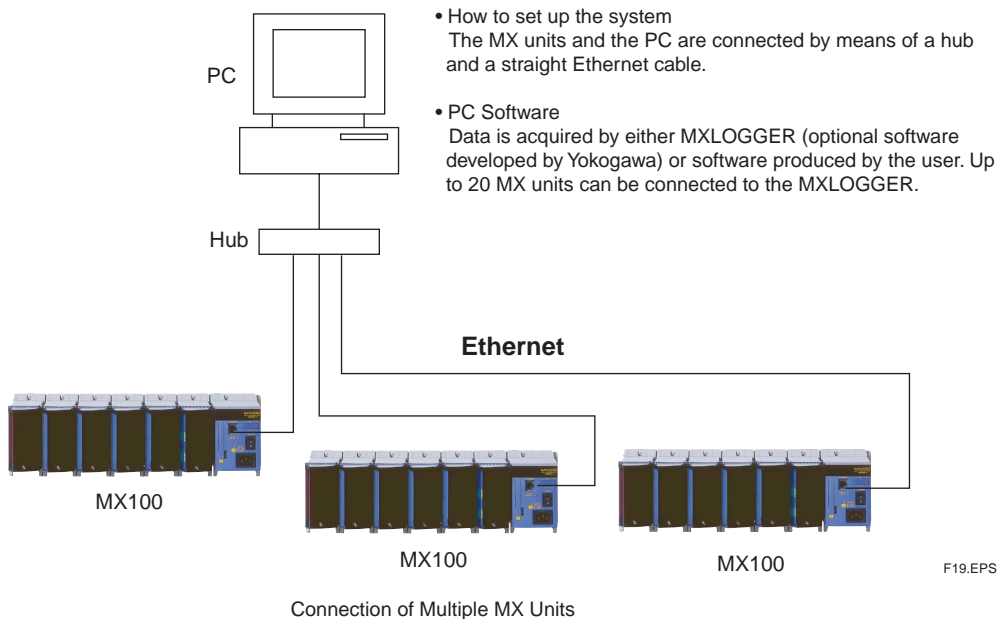

The following conditions must be met when constructing a system with DAQMASTER and PC software developed by Yokogawa.

**The release number of PC software  $\geq$  The style number of the main module  $\geq$  The style number of the input/output module**

- The style number of the main module must be the same or higher than the style number of each input/output module that will be connected to it.
- The release number of the PC software and related products must be the same or higher than the style number of the main module with which it will be connected.



Configuration Examples:

Correct: MX100 Standard Software R2.01, MX100 S1, and MX110-UNV-M10 S1.

Correct: MXLOGGER R2.01, MX100 S2, and MX112-B12-M04 S2

Incorrect: MX100 Standard Software R2.01, MX100 S1, and MX112-B12-M04 S2.

Incorrect: MXLOGGER R1.03, MX100 S2, and MX112-B12-M04 S2

You can ascertain the style numbers of the main module and input/output module on the main name plate, and the release number of the PC software on the face of the CD or in the Help menu of the software program.

(3) Definitions of unit no., slot no. and channel no.

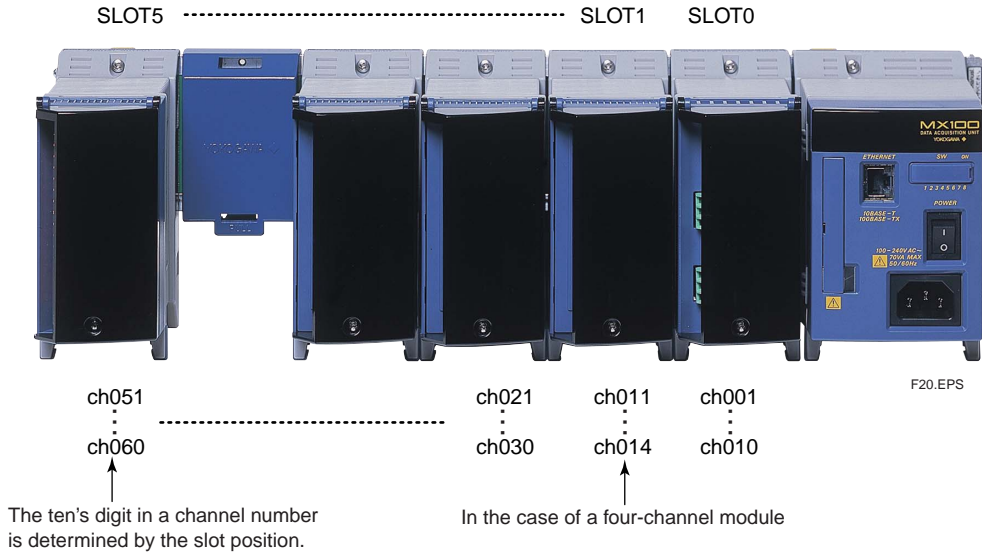

How to describe channel numbers:

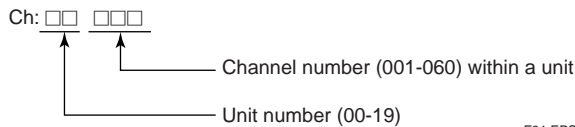

■ Functional Overview

- Input types: DC voltage, temperature (TC, 3-wire RTD, 4-wire RTD), digital (non-voltage contact, open collector, level(5 V logic, 24 V logic)), strain, resistance
- Output types: "A" contact (SPST), DC voltage, DC current, PWM (pulse width modulation)
- Number of measurement points: Up to 60 channels per unit. Multiple units are integrated by PC software.
- Number of output points: Up to 60 channels per unit. Multiple units are integrated by PC software.
- Measurement interval: The shortest measurement interval is 10 ms. It depends on the types of modules and number of measurement points.
- Multi-interval: Possible to set different measurement intervals per module and to set up to three types in a system
- Computation: To be performed by PC software (some functions are performed in the main unit)
- Display: To be performed by PC software
- Settings: To be performed by PC software
- Save: To the PC. If communication between the PC and the main unit is interrupted, data is saved to the CF card.
- Interface: 100 Base-TX/10 Base-T Ethernet

An input module performs measurement according to specified measurement intervals. The main module acquires measured data every 100 ms at maximum speed. The main module transfers the data to the PC after the computations for compensation, physical volume conversions, etc. Also, if I/O occurs within a single unit regardless of the number of units to be connected to a single PC, contact output when the main module detects an alarm and retransmission of measured values can be performed by the module independently of the PC.

The PC software (in the case of software developed by Yokogawa) acquires data from the main module. It also performs computations, displays or saves data. If necessary, it generates output commands to produce digital outputs and analog outputs from output modules via the main module. (alarm and other output occurs across units.)

## ■ Hardware Specifications

### Common Specifications

- **Normal operating conditions**

Operating temperature range: 0-50°C  
 Operating humidity range: 20-80% RH for 0-40°C  
 10-50% RH for 40-50°C  
 Rated power supply voltage: AC power supply, 100-240 VAC  
 Range of operating power supply voltage: AC power supply, 90-250 VAC  
 Power supply frequency: 50 Hz ±2%, 60 Hz ±2%  
 Power consumption: Up to approximately 70 VA when six modules are used  
 Vibration: 10-60 Hz, 0.2m/s<sup>2</sup> or less  
 Shock: Not tolerated  
 Magnetic field: 400 A/m or less (50/60 Hz)  
 Attitude: To be used horizontally with legs extended downward  
 Location for use: Indoors  
 Altitude for use: 2,000 m or less  
 Overvoltage category: II (according to IEC61010-1)  
 Measurement category: II (according to IEC61010-1)  
 Degree of pollution: 2

- **Conditions for transportation and storage**

Environmental conditions for the transportation/storage of equipment from the time of delivery until the start of use, as well as for the transportation/storage when the use of equipment is temporarily suspended.  
 Ambient temperature during storage: -25-60°C  
 Ambient humidity during storage: 5-95%  
 Vibration: 10-60 Hz, 4.9 m/s<sup>2</sup> or less  
 Shock: 392 m/s<sup>2</sup> or less (in a packaged condition)

- **Mechanical specifications**

External dimensions: Approx. 442 × 131 × 159 mm (when six slots are attached)  
 Weight: Approx. 4.1 kg (maximum total weight)  
 How to mount: Desktop/on the floor/  
 Panel mount with DIN rails  
 Material: Steel plate, aluminum die-cast, plastic mold resin

- **Supported standards**

CSA	Obtained CSA22.2 No.61010-1, Overvoltage category: II, Measurement category: II, Degree of pollution: 2	
UL	Obtained UL61010B-1 (CSA NRTL/C)	
CE	EMC directive	EN61326 EN61000-3-2 EN61000-3-3 EN55011 Class A Group 1
	Low voltage directive	EN61010-1 Overvoltage category: II, Measurement category: II, Degree of pollution: 2
C-Tick	AS/NZS CISPR11 Class A Group 1	

T01.EPS



**Model-Specific Specifications**

• **Main module (MX100)**

Style number: S2

Main functions: Control of the input/output modules, communication with the PC, storage of data on the CF card (during a communication failure), supply of power.

Number of maximum connectable input/output modules: 6 (arbitrary for six modules or less)

Measurement interval: Up to three types can be set to a system (multi-interval)

Types of measurement intervals are 10/50/100/200/500 ms, 1/2/5/10/20/30/60 s

Note that configurable measurement intervals differ depending on modules.

Transfer cycle of measured data to the PC: Minimum 100 ms

Synchronization between modules: Synchronized within the same measurement interval (within the same unit)

Synchronization between channels: Synchronized between channels in the same module for the Four-Channel High-Speed Universal Input Module (MX110-UNV-H04), and the Ten-Channel High-Speed Digital Input Module (MX115).

Not synchronized between channels for the Ten-Channel Medium-Speed Universal Input Module (MX110-UNV-M10), Six-Channel Medium-Speed 4-Wire RTD and Resistance Input Module (MX110-V4R-M06) and Four-Channel Medium-Speed Strain Input Module (MX112-xxx-M04), because it is a scanner-type module.

Time stamp for measured data: Both the time stamp of the main module and the time stamp sent from the PC are used.

Filter function: First-order lag filter. The function can be set for each channel. Time constant = measurement interval × N (where N is any number of the following: 5, 10, 20, 25, 40, 50, and 100). Choose a time constant corresponding to a measurement interval from the table on the next page:

**List of Time Constants**

Measurement interval (sec.)	Time Constant (sec.)						
	N=5	N=10	N=20	N=25	N=40	N=50	N=100
0.01	0.05	0.1	0.2	0.25	0.4	0.5	1
0.05	0.25	0.5	1	1.25	2	2.5	5
0.1	0.5	1	2	2.5	4	5	10
0.2	1	2	4	5	8	10	20
0.5	2.5	5	10	12.5	20	25	50
1	5	10	20	25	40	50	100
2	10	20	40	50	80	100	200
5	25	50	100	125	200	250	500
10	50	100	200	250	400	500	1000
20	100	200	400	500	800	1000	2000
30	150	300	600	750	1200	1500	3000
60	300	600	1200	1500	2400	3000	6000

T02.EPS

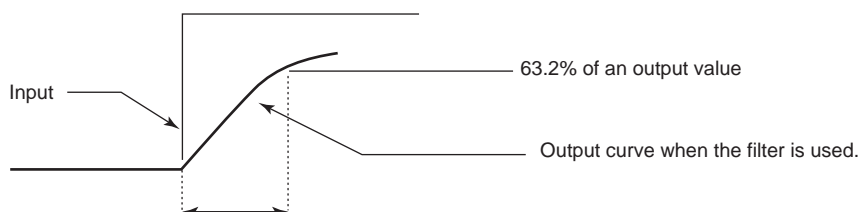

- A time constant described in the above (List of Time Constants).
- Time required to achieve 63.2% of an output value.

F22.EPS

**Input computation function (computation function that can be executed in the main module)**

Computation of differences between channels: differential computation between arbitrary channels (DCV, TC, RTD, strain, resistance, DI; also possible when the scaling is set)

Linear scaling computation:

Possible range for scaling: DCV, TC, RTD, strain, resistance, DI

Possible scope for scaling: -30000-30000

Position of the decimal point: any digit (0-4)

**Alarm (alarm function can be executed in the main module. This function is enabled even during a communication failure).**

Alarm types: Upper limit, lower limit, differential upper limit, and differential lower limit

Number of settings: two items per channel

Possible range for alarm setting: DCV, TC, RTD, strain, resistance, DI, scaling

Hysteresis: Alarm "ON/OFF" values are set arbitrarily.

Number of alarm output points: 10-60 points according to the number of mounted "DO" modules

Output mode: Excitation/non-excitation, OR\*<sup>1</sup>, hold/non-hold, and command output\*<sup>2</sup>

\*<sup>1</sup> With the MX100 Standard Software, OR output is possible within a single channel.  
(Alarm1 and OR of Alarm2)

\*<sup>2</sup> At least 100 ms is required for the response time for detecting changes in the command output.

**Output function:** command output, retransmission output

#### **Saving the data**

Save function: Backup in case of a communication failure during data acquisitions by the PC.

Supported external media: CF Card (up to 2 GB) Type I, II × one slot

Save trigger: While the PC is storing data and also when timeout (60 s) is detected after a communication failure.

If communication is restored before a timeout, the Yokogawa's dedicated software (MX100 Standard Software or MXLOGGER) reads the data from the main module buffer that was acquired when the communication was cut, and stores it. In this case, data is not stored to the CF card.

Timeout time: Fixed at 60 s when using Yokogawa's dedicated software (MX100 Standard Software or MXLOGGER).

Setting of 60 s or higher are possible when using the API.

Save channel: A channel being monitored by the PC is saved.

Save cycle: Data is saved automatically (60 s)

Stopping the save function: If the PC's data acquisition is recovered or if the CF Switch is pressed.

Data guarantee during a power failure: Guaranteed until data is written immediately before the MX is turned off (for example, power failure).

Without /DS option: The backup operation will not continue after the system recovers from a power failure.

With /DS option: The backup operation will continue after the system recovers from a power failure.

Data length: 4 bytes/channel

Data file: 5 Mbytes/file (data is saved automatically up to 5 Mbytes). Data files are created for the number of measurement intervals (number of multi-intervals). When the size of the files at the highest speed reaches 5 Mbytes, files of other measurement intervals are closed. Then, new files are created according to save cycle (60 s).

Equation for calculating the size of the saved file:

Size of the saved file (bytes) = header size + (data size × write count)

Header size = 416 bytes + channel information × the number of saved channels

Channel Information: Style number S1 is 176 bytes, S2 is 184 bytes.

Data size = 4 bytes × the number of saved channels × sample count

Sample count = Save interval (s)/measurement interval (s)

Write count = ((5 Mbytes – header size)/ (data size)) or less

(Truncated to an integer)

Format: Only the quick (logic) format is supported.

File system: FAT

File save folder: Route (Up to 512 files can be saved.)

Reference Information for Sampling Time by CF Card Size

Number of saved channels	Measurement interval	32 MB	64 MB	128 MB	256 MB	512 MB
10 channels	10 ms	2 hours	4 hours	9 hours	18 hours	36 hours
	50 ms	10 hours	21 hours	45 hours	3 days	7 days
	100 ms	21 hours	43 hours	3.5 days	7 days	15 days
	200 ms	43 hours	3 days	7 days	15 days	30 days
	500 ms	4.5 days	9 days	18.5 days	38 days	75.5 days
	1 s	9 days	18 days	37 days	77 days	154 days
	2 s	18 days	36 days	75.5 days	154 days	303 days
24 channels	10 ms	54 minutes	100 minutes	3.5 hours	7 hours	15 hours
	50 ms	4 hours	9 hours	18 hours	38 hours	77 hours
	100 ms	9 hours	18 hours	37 hours	77 hours	6 days
	200 ms	18 hours	36 hours	75 hours	6 days	12 days
	500 ms	45 hours	3 days	7.5 days	16 days	31.5 days
	1 s	3 days	7 days	15 days	32 days	64 days
	2 s	7.5 days	15 days	31.5 days	64 days	126 days
60 channels	10 ms	18 minutes	40 minutes	75 minutes	3 hours	5 hours
	50 ms	1 hour	3 hours	7 hours	15 hours	30 hours
	100 ms	3.5 hours	7 hours	15 hours	30 hours	2.5 days
	200 ms	7 hours	14 hours	30 hours	2 days	5 days
	500 ms	18 hours	36 hours	3 days	6 days	12.5 days
	1 s	36 hours	3 days	6 days	12 days	25 days
	2 s	3 days	6 days	12.5 days	25 days	50 days

Note: Minutes/hours/days are approximate.

T03.EPS

**/DS Option Functions**

The following three functions are available with the /DS option.

Operation mode automatic retention function: When the power is turned ON, the operation mode active when the power was cut is restored.

Switch control of measurement and CF recording (saving data without a PC): Start/stop of measurement and recording to the CF card can be performed by holding down the CF switch for five seconds.

Dual save function (simultaneous saving of data to the PC and to the CF card): When the shortest measurement interval is set to 100 ms or more, output of data to the PC via communications and saving of data to the CF card in the MX (CF recording) can be carried out simultaneously. CF recording is linked with start/stop commands from the PC (this function is not available if a measurement interval of 100 ms or more and 10 ms/50 ms is set at the same time).

**Display**

LED: Indication of Ethernet status.

Orange: LINK, connected. Green: ACT, data being transmitted/received

7-segment indication: MX status indication by 7 segments in 2 digits (Unit No., operation status indication, indication of error occurrence, indication of messages concerning the CF Card, etc.)

**Communication functions**

Interface: 100 Base-TX/10 Base-T (automatic detection) Ethernet

Basic protocol: TCP, IP, UDP, ARP, ICMP

Transmission function: Transmission of measured values and setting values

Receiving function: Reception of setting values and command output values

**Other functions**

Accuracy of internal clock: ±100 ppm. The delay (one second or less) that occurs every time the power supply is turned on/off is not included.

Switch: 8-bit dip switch (for IP address initialization, etc.)

**General specifications**

Power consumption: Approximately 8 W for main module only  
Insulation resistance: 20 M $\Omega$  or more (500 VDC) between the power supply terminal and the ground terminal  
Withstand voltage: 1500 VACrms (50/60 Hz) between the power supply terminal and the ground terminal, one minute  
External dimension: Approximately 92 × 131 × 137 mm  
Weight: Approximately 0.85 kg

• **Base Plate (MX150)**

Number of main modules that can be equipped: 1 (always equipped)  
Number of I/O modules that can be equipped: 1-6 (to be specified according to the suffix codes)

• Four-Channel High-Speed Universal Input Module (MX110-UNV-H04)

Style number: S1

Types of measurement: DC voltage, thermocouple, 3-wire RTD, DI (non-voltage contact, level (5 V logic))

Number of measurement points: 4 (Each channel is equipped with an independent A/D converter. (for a total of four on a single module))

Input method: Floating unbalanced input, isolation between channels

A/D resolution: ±20000/±6000 (16-bit A/D is used)

Measurement interval and A/D integral time: A/D integral time is determined by measurement intervals

Measurement interval	Integral time	Noise rejection/remarks
10 ms <sup>(1)</sup>	1.67 ms <sup>(2)</sup>	600 Hz and its integer multiples
50 ms	16.67 ms	60 Hz and its integer multiples
	20 ms	50 Hz and its integer multiples
	Auto	Power supply frequency is automatically detected and is set to 16.67/20 ms automatically.
100 ms	36.67 ms	50/60 Hz, and the respective integer multiples
200 ms		
500 ms	100 ms	10 Hz and its integer multiples
1 s	200 ms	Fc = 5 Hz low pass filter
2, 5, 10, 20, 30, 60 s		

T04.EPS

(\*1) Temperature measurements cannot be taken using MX100 Standard Software. However, temperature measurements are possible with MXLOGGER and programs using the API.

(\*2) If thermocouple measurements are taken at an integral time of 1.67 ms, the measured values may be susceptible to inaccuracies due to power supply frequency noise. If this is the case, set the integral time to 16.67 ms or longer (for a power supply frequency of 60 Hz), or 20 ms or longer (for a power supply frequency of 50 Hz). On this module, the power supply frequency noise can be rejected by selecting a measurement interval of 50ms or more. (on DAQMASTER, the integral time is automatically set when selecting the measurement interval.)

**Measurement Ranges and Accuracies**

The accuracy applies to standard operating conditions: ambient temp: 23 ±2°C, ambient humidity: 55 ±10% RH, supply voltage: 90 to 250 VAC, power frequency: 50/60 Hz ±1%, warm-up time: at least 30 minutes, without adverse conditions such as vibrations.

Input	Type	Rated measurement range	Measurement accuracy integral time 16.67 ms or more	Measurement accuracy integral time 1.67 ms	Maximum resolution (1 digit)		
DC voltage	20 mV	-20.000 to 20.000 mV	±(0.05% of rdg. + 5 digits)	±(0.1% of rdg. + 25 digits)	1 μV		
	60 mV	-60.00 to 60.00 mV	±(0.05% of rdg. + 2 digits)	±(0.1% of rdg. + 10 digits)	10 μV		
	200 mV	-200.00 to 200.00 mV			10 μV		
	2 V	-2.0000 to 2.0000 V	±(0.05% of rdg. + 5 digits)		100 μV		
	6 V	-6.000 to 6.000 V	±(0.05% of rdg. + 2 digits)		1 mV		
	20 V	-20.000 to 20.000 V			1 mV		
	100 V	-100.00 to 100.00 V			10 mV		
Thermocouple (excludes RJC accuracy, when burnout is OFF)	R *1	0.0 to 1760.0°C			±(0.05% of rdg. + 1°C) However, R, S: 0 to 100°C: ±3.7°C 100 to 300°C: ±1.5°C B: 400 to 600°C: ±2°C Less than 400°C: accuracy not guaranteed	±(0.1% of rdg. + 4°C) *10 However, R,S: 0 to 100°C: ±10°C 100 to 300°C: ±5°C B: 400 to 600°C: ±7°C Less than 400°C: accuracy not guaranteed	0.1°C
	S *1						
	B *1	0.0 to 1820.0°C	±(0.05% of rdg. + 0.7°C) However, -200 to -100°C: ±(0.05% of rdg. + 1°C)	±(0.1% of rdg. + 3.5°C) *10 However, -200 to -100°C: ±(0.1% of rdg. + 6°C)			
	K *1	-200.0 to 1370.0°C					
	E *1	-200.0 to 800.0°C					
	J *1	-200.0 to 1100.0°C					
	T *1	-200.0 to 400.0°C					
	L *2	-200.0 to 900.0°C					
	U	-200.0 to 400.0°C					
	N *3	0.0 to 1300.0°C					
	W *4	0.0 to 2315.0°C					
	KPvsAu7Fe	0.0 to 300.0 K			±(0.05% of rdg. + 0.7 K)	±(0.1% of rdg. + 3.5 K) *10	
3-wire RTD (Measurement current 1 mA)	Pt100 *5	-200.0 to 600.0°C	±(0.05% of rdg. + 0.3°C)	±(0.1% of rdg. + 1.5°C)	0.1°C		
	JPt100 *5	-200.0 to 550.0°C					
	Pt100 (high resolution)	-140.00 to 150.00°C					
	JPt100 (high resolution)	-140.00 to 150.00°C					
	Ni100SAMA *6	200.0 to 250.0°C					
	Ni100 DIN *6	-60.0 to 180.0°C					
	Ni120 *7	-70.0 to 200.0°C					
3-wire RTD (Measurement current 2 mA)	Pt100 *5	-200.0 to 250.0°C	±(0.05% of rdg. + 0.3°C)	±(0.1% of rdg. + 1.5°C)	0.1°C		
	JPt100 *5	-200.0 to 250.0°C					
	Pt100 (high resolution)	-140.00 to 150.00°C					
	JPt100 (high resolution)	-140.00 to 150.00°C					
	Pt50 *5	-200.0 to 550.0°C					
	Cu10 GE *8	-200.0 to 300.0°C			±(0.1% of rdg. + 0.7°C)	±(0.2% of rdg. + 2.5°C)	0.1°C
	Cu10 L&N *8	-200.0 to 300.0°C					
	Cu10 WEED *8	-200.0 to 300.0°C					
Cu10 BAILEY *8	-200.0 to 300.0°C						
J263B	0.0 to 300.0 K	±(0.05% of rdg. + 0.3 K)	±(0.1% of rdg. + 1.5 K) *10	0.1 K			
DI	Level	Vth = 2.4 V	Threshold level accuracy ±0.1 V				
	Non-voltage contact	100 Ω or less: ON, 10 kΩ or more: OFF *9					

\*1 R, S, B, K, E, J, T: ANSI, IEC 584, DIN IEC 584, JIS C 1602-1981

\*2 L: Fe-CuNi, DIN43710/U: Cu-CuNi, DIN 43710

\*3 N: Nicrosil-Nisil, IEC 584, DIN IEC 584

\*4 W: W-5%RE-W-26%Re (Hoskins Mfg Co)

\*5 Pt50: JIS C 1604-1981, JIS C 1606-1986/Pt100: JIS C 1604-1989, JIS C 1606-1989, IEC 751, DIN IEC 751/JPt100: JIS C 1604-1981, JIS C 1606-1989

\*6 SAMA/DIN

\*7 McGRAW EDISON COMPANY

\*8 Guaranteed accuracy range Cu10 GE: -84.4 to 170.0°C/Cu10 L&N: -75.0 to 150.0°C/Cu10 WEED: -20.0 to 250.0°C/Cu10 BAILEY: -20.0 to 250.0°C

\*9 To be determined at the measurement current of 1 mA and within the range of 2 V. The threshold level is approximately 0.8 V.

\*10 The measurement accuracy with MXLOGGER and programs using the API. Measurement not possible when using MX100 Standard Software.

T05.EPS



**Measurement Ranges and Accuracies (continued)**

The ranges below can be used for MXLOGGER (optional software) or API.

Input	Type	Rated measurement range	Measurement accuracy integral time 16.67 ms or more	Measurement accuracy integral time 1.67 ms	Maximum resolution (1 digit)
DC voltage	60 mV (high resolution)	0.000 to 60.000 mV	±(0.05% of rdg. + 20 digits)	±(0.1% of rdg. + 100 digits)	1 μV
	1 V	-1.0000 to 1.0000 V	±(0.05% of rdg. + 2 digits)	±(0.1% of rdg. + 10 digits)	100 μV
	6 V (high resolution)	0.0000 to 6.0000 V	±(0.05% of rdg. + 20 digits)	±(0.1% of rdg. + 100 digits)	100 μV
Thermocouple (excludes RJC accuracy, when burnout is OFF)	PLATINEL	0.0 to 1400.0°C	±(0.05% of rdg. + 1°C)	±(0.1% of rdg. + 4°C)	0.1°C
	PR40-20 *1	0.0 to 1900.0°C	±(0.05% of rdg. + 2.5°C) However, 300 to 700°C: ±6°C Less than 300°C: accuracy not guaranteed	±(0.1% of rdg. + 12°C) However, 300 to 700°C: ±25°C Less than 300°C: accuracy not guaranteed	
	NiNiMo	0.0 to 1310.0°C	±(0.05% of rdg. + 0.7°C)	±(0.1% of rdg. + 2.7°C)	
	WRe3-25	0.0 to 2400.0°C	±(0.05% of rdg. + 2°C) However, 0 to 200°C: ±2.5°C 2000°C or more: ±(0.05% of rdg. + 4°C)	±(0.1% of rdg. + 7°C) However, 0 to 200°C: ±12°C 2000°C or more: ±(0.1% of rdg. + 11°C)	
	W/WRe26	0.0 to 2400.0°C	±(0.05% of rdg. + 2°C) However, 100 to 300°C: ±4°C Less than 100°C: accuracy not guaranteed	±(0.1% of rdg. + 8.5°C) However, 100 to 300°C: ±12°C Less than 100°C: accuracy not guaranteed	
	Type-N (AWG14)	0.0 to 1300.0°C	±(0.05% of rdg. + 0.7°C)	±(0.1% of rdg. + 3.5°C)	
3-wire RTD (Measurement current 1 mA)	Pt100 (high noise resistance)	-200.0 to 600.0°C	±(0.05% of rdg. + 0.3°C)	±(0.1% of rdg. + 2.5°C)	0.1°C
	JPt100 (high noise resistance)	-200.0 to 550.0°C			
3-wire RTD (Measurement current 2 mA)	Cu10 at 20°C alpha=0.00392	-200.0 to 300.0°C	±(0.1% of rdg. + 0.7°C)	±(0.2% of rdg. + 2.5°C)	0.1°C
	Cu10 at 20°C alpha=0.00393	-200.0 to 300.0°C			
	Cu25 at 0°C alpha=0.00425	-200.0 to 300.0°C	±(0.1% of rdg. + 0.5°C)	±(0.2% of rdg. + 2°C)	0.1°C
	Cu53 at 0°C alpha=0.00426035	-50.0 to 150.0°C	±(0.05% of rdg. + 0.3°C)	±(0.1% of rdg. + 1.5°C)	0.1°C
	Cu100 at 0°C alpha=0.00425	-50.0 to 150.0°C			
	Pt25(JPt100×1/4)	-200.0 to 550.0°C	±(0.1% of rdg. + 0.5°C)	±(0.2% of rdg. + 2°C)	0.1°C
	Cu10 GE *2 (high resolution)	-200.0 to 300.0°C	±(0.1% of rdg. + 0.7°C)	±(0.2% of rdg. + 2.5°C)	0.1°C
	Cu10 L&N *2 (high resolution)	-200.0 to 300.0°C			
	Cu10 WEED *2 (high resolution)	-200.0 to 300.0°C			
	Cu10 BAILEY *2 (high resolution)	-200.0 to 300.0°C			
	Pt100 (high noise resistance)	-200.0 to 250.0°C	±(0.05% of rdg. + 0.3°C)	±(0.1% of rdg. + 1.5°C)	0.1°C
JPt100 (high noise resistance)	-200.0 to 250.0°C				

\*1 PR40-20: PtRh20%-PtRh40% (John Matthey Plc)

\*2 Guaranteed accuracy range Cu10 GE: -84.4 to 170.0°C/Cu10 L&N: -75.0 to 150.0°C/Cu10 WEED: -20.0 to 250.0°C/Cu10 BAILEY: -20.0 to 250.0°C

T06.EPS

- Reference junction compensation:  
External/internal switchover can be performed for each channel.  
The Remote RJC function is available.
- Reference junction compensation accuracy:  
During the measurement of 0°C or more and during the input terminal temperature balance  
Type R, S, W:  $\pm 1^\circ\text{C}$   
Type K, J, E, T, N, L, U:  $\pm 0.5^\circ\text{C}$   
Type N (AWG14), PLATINEL, NiNiMo, WRe3-25, W/WRe26:  $\pm 1^\circ\text{C}$   
Internal reference junction compensation for Type B and PR40-20 is fixed to 0°C.
- Maximum input voltage:  
1 VDC range or less, thermocouple, RTD, DI (contact only):  $\pm 10$  VDC (continuous)  
Other measurement ranges:  $\pm 120$  VDC (continuous)
- Normal mode voltage:  
DCV, TC, DI (level): 1.2 times of rated range or less (50/60 Hz, peak values including signals)  
RTD 100  $\Omega$  system: 50 mV peak  
RTD 10, 25, 50  $\Omega$  systems: 10 mV peak
- Normal mode rejection ratio (NMRR):  
40 dB or more when the integral time is 16.67 ms or more (50/60 Hz  $\pm 0.1\%$ )  
50/60 Hz is not rejected when the integral time is 1.67 ms.
- Common mode voltage:  
600 VACrms (50/60 Hz), reinforced (double) insulation
- Common mode rejection ratio (CMRR):  
120 dB or more when the integral time is 16.67 ms or more  
80 dB or more when the integral time is 1.67 ms  
(50/60 Hz  $\pm 0.1\%$ , 500  $\Omega$  imbalance, between the minus measurement terminal and ground)
- Common mode between channels:  
250 VACrms (50/60 Hz), reinforced (double) insulation
- Noise rejection: Rejection by the integrating A/D and the use of low pass filters
- Input resistance: 10 M $\Omega$  or more for the DC voltage of 1 V range or less and also for the thermocouple range  
Approximately 1 M $\Omega$  if the DC voltage is 2 V range or more  
Approximately 1 M $\Omega$  while the measurement operation is stopped
- Insulation resistance:  
20 M $\Omega$  or more between the input and ground (500 VDC)
- Input bias current: 10 nA or less (except for the burn-out setting)
- Withstand voltage:  
2300 VACrms (50/60 Hz) between input terminals, one minute  
3700 VACrms (50/60 Hz) between an input terminal and ground, one minute
- Input signal source resistance:  
2 k $\Omega$  or less for DC voltage and thermocouple  
10  $\Omega$  or less per cable for RTD 50  $\Omega$  or 100  $\Omega$  systems  
1  $\Omega$  or less per cable for RTD 10  $\Omega$  or 25  $\Omega$  systems
- Thermocouple burn-out:  
Superposed electric current system, detection within the thermocouple range ("ON/OFF" possible), the up/down setting possible, detection current at approximately 100 nA, 2 k $\Omega$  or less being normal, and 10 M $\Omega$  or more being disconnected.  
Influence on measurement accuracy:  $\pm 15$   $\mu\text{V}$  or less (influence on signal source resistance is not included)
- Parallel capacity during RTD: 0.01  $\mu\text{F}$  or less
- Power consumption: Approximately 3 W
- External dimension: Approximately 57  $\times$  131  $\times$  151 mm (including the terminal cover)
- Weight: Approximately 0.5 kg
- Terminal type: Clamp terminal. Attachable/detachable per channel.
- Applicable cable size: 0.2-2.5 mm<sup>2</sup> (AWG24-12)

**Influence of operating conditions (applicable if the integral time is 16.67 ms or more)**

Warm-up time: 30 minutes or more after the power supply is turned on.

Influence of ambient temperature:

Influence on a change in ambient temperature of 10°C is within  $\pm(0.05\%$  of rdg. + 0.05% of range). However, during Cu10  $\Omega$  :  $\pm(0.2\%$  of range + 1 digit)

Influence of power supply fluctuations:

Specifications of accuracy are satisfied at AC power 90-132 V or 180-250 V

Influence of external magnetic fields:

Fluctuations on external magnetic fields of alternate current (50/60 Hz) 400 A/m are  $\pm(0.1\%$  of rdg. + 10 digits) or less.

Influence of signal source resistance:

Influences on fluctuations of signal source resistance (1 k $\Omega$ ) of voltage and thermocouple are:

Voltage: 1 V range or less

$\pm 10 \mu\text{V}$  or less

2 V range or more

$\pm 0.15\%$  of rdg. or less

Thermocouple:  $\pm 10 \mu\text{V}$  or less. However,  $\pm 150 \mu\text{V}$  or less when the burn-out is set

RTD: Fluctuation (one common resistance value for three cables) on a change of 10  $\Omega$  per cable for 100  $\Omega$  systems is  $\pm 0.1^\circ\text{C}$  or less ( $\pm 1.0^\circ\text{C}$  or less for other systems).

Fluctuation on the difference of 40 m $\Omega$  in resistance values among conductors (maximum difference among three cables) shall be approximately  $0.1^\circ\text{C}$  (for Pt100)

Influence of attitude:

Basically, the system shall be used in a horizontal position with its legs extended downward.

Influence of vibrations:

Fluctuations when sine wave vibrations in the frequency of 10-60 Hz and at an acceleration of 0.2 m/s<sup>2</sup> are applied for two hours respectively in three axis directions shall be  $\pm(0.1\%$  of rdg. + 1 digit) or less.

• Ten-Channel Medium-Speed Universal Input Module (MX110-UNV-M10)

Style number: S1

Types of measurement: DC voltage, thermocouple, 3-wire RTD, DI (non-voltage contact, level (5 V logic))

Number of measurement points: 10 (scanning of 10 channels with one A/D)

Input method: Floating unbalanced input, isolation between channels (Note that RTD is common among “b” terminals.)

A/D resolution: ±20000/±6000 (16-bit A/D is used)

Measurement interval and A/D integral time: A/D integral time is determined by measurement intervals.

Measurement interval	Integral time	B.O. detection cycle	Noise rejection /remarks
100 ms	1.67 ms <sup>(*2)</sup>	1 s <sup>(*1)</sup> Measurement interval	600 Hz and its integer multiples
200 ms			60 Hz and its integer multiples
500 ms	16.67 ms		50 Hz and its integer multiples
	20 ms		Power supply frequency is automatically detected and is set to 16.67/20 ms
	Auto		50/60 Hz and the respective integer multiples
1 s	36.67 ms		10 Hz and its integer multiples
2 s	100 ms		Fc = 5 Hz low pass filter
5 s	200 ms		
10, 20, 30, 60 s			

T07.EPS

(\*1) This is because the burn-out cannot be detected until up to 10 measurements have occurred (about one second) if measurement is started in the burn-out state. (If a measurement interval is 100 ms, the burn-out detection executed in one measurement interval is for one channel only.)

(\*2) If thermocouple measurements are taken at an integral time of 1.67 ms, the measured values may be susceptible to inaccuracies due to power supply frequency noise. If this is the case, set the integral time to 16.67 ms or longer (for a power supply frequency of 60 Hz), or 20 ms or longer (for a power supply frequency of 50 Hz). On this module, the power supply frequency noise can be rejected by selecting a measurement interval of 500ms or more. (on DAQMASTER, the integral time is automatically set when selecting the measurement interval.)

**Measurement Ranges and Accuracies**

The accuracy applies to standard operating conditions: ambient temp: 23 ±2°C, ambient humidity: 55 ±10% RH, supply voltage: 90 to 250 VAC, power frequency: 50/60 Hz ±1%, warm-up time: at least 30 minutes, without adverse conditions such as vibrations.

Input	Type	Rated measurement range	Measurement accuracy integral time 16.67 ms or more	Measurement accuracy integral time 1.67 ms	Maximum resolution (1 digit)	
DC voltage	20 mV	-20.000 to 20.000 mV	±(0.05% of rdg. + 5 digits)	±(0.1% of rdg. + 25 digits)	1 µV	
	60 mV	-60.00 to 60.00 mV	±(0.05% of rdg. + 2 digits)		10 µV	
	200 mV	-200.00 to 200.00 mV			10 µV	
	2 V	-2.0000 to 2.0000 V	±(0.05% of rdg. + 5 digits)		±(0.1% of rdg. + 10 digits)	100 µV
	6 V	-6.000 to 6.000 V	±(0.05% of rdg. + 2 digits)			1 mV
	20 V	-20.000 to 20.000 V				1 mV
	100 V	-100.00 to 100.00 V				10 mV
Thermocouple RJC accuracy not included	R *1	0.0 to 1760.0°C		±(0.05% of rdg. + 1°C) However, R, S: 0 to 100°C: ±3.7°C 100 to 300°C: ±1.5°C B: 400 to 600°C: ±2°C Less than 400°C: accuracy not guaranteed		±(0.1% of rdg. + 4°C) However, R, S: 0 to 100°C: ±10°C 100 to 300°C: ±5°C B: 400 to 600°C: ±7°C Less than 400°C: accuracy not guaranteed
	S *1					
	B *1	0.0 to 1820.0°C	±(0.05% of rdg. + 0.7°C) However, -200 to -100°C: ±(0.05% of rdg. + 1°C)	±(0.1% of rdg. + 3.5°C) However, -200 to -100°C: ±(0.1% of rdg. + 6°C)		
	K *1	-200.0 to 1370.0°C				
	E *1	-200.0 to 800.0°C				
	J *1	-200.0 to 1100.0°C				
	T *1	-200.0 to 400.0°C				
	L *2	-200.0 to 900.0°C				
	U	-200.0 to 400.0°C				
	N *3	0.0 to 1300.0°C				
	W *4	0.0 to 2315.0°C				
	KPvsAu7Fe	0.0 to 300.0 K			±(0.05% of rdg. + 0.7 K)	±(0.1% of rdg. + 3.5 K)
3-wire RTD (Measurement current 1 mA)	Pt100 *5	-200.0 to 600.0°C			±(0.05% of rdg. + 0.3°C)	±(0.1% of rdg. + 1.5°C)
	JPt100 *5	-200.0 to 550.0°C				
	Pt100 (high resolution)	-140.00 to 150.00°C	±(0.05% of rdg. + 0.3°C)	±(0.1% of rdg. + 1.5°C)	0.01°C	
	JPt100 (high resolution)	-140.00 to 150.00°C				
	Ni100SAMA *6	-200.0 to 250.0°C	±(0.05% of rdg. + 0.3°C)	±(0.1% of rdg. + 1.5°C)	0.1°C	
	Ni100 DIN *6	-60.0 to 180.0°C				
	Ni120 *7	-70.0 to 200.0°C				
	Pt50 *5	-200.0 to 550.0°C				
	Cu10 GE *8	-200.0 to 300.0°C	±(0.1% of rdg. + 2°C)	±(0.2% of rdg. + 5°C)	0.1°C	
	Cu10 L&N *8	-200.0 to 300.0°C				
	Cu10 WEED *8	-200.0 to 300.0°C				
	Cu10 BAILEY *8	-200.0 to 300.0°C				
J263B	0.0 to 300.0 K	±(0.05% of rdg. + 0.3 K)	±(0.1% of rdg. + 1.5 K)	0.1 K		
DI	Level	V <sub>th</sub> = 2.4 V	Threshold level accuracy ±0.1 V			
	Non-voltage contact	1 kΩ or less: ON, 100 kΩ or more: OFF (parallel capacity is 0.01 µF or less) *9				

\*1 R, S, B, K, E, J, T: ANSI, IEC 584, DIN IEC 584, JIS C 1602-1981

T08.EPS

\*2 L: Fe-CuNi, DIN43710/U: Cu-CuNi, DIN 43710

\*3 N: Nicrosil-Nisil, IEC 584, DIN IEC 584

\*4 W: W-5%RE-W-26%Re (Hoskins Mfg Co)

\*5 Pt50: JIS C 1604-1981, JIS C 1606-1986/Pt100: JIS C 1604-1989, JIS C 1606-1989, IEC 751, DIN IEC 751/JPt100: JIS C 1604-1981, JIS C 1606-1989

\*6 SAMA/DIN

\*7 McGRAW EDISON COMPANY

\*8 Guaranteed accuracy range Cu10 GE: -84.4 to 170.0°C/Cu10 L&N: -75.0 to 150.0°C/Cu10 WEED: -20.0 to 250.0°C/Cu10 BAILEY: -20.0 to 250.0°C

\*9 To be determined at the measurement current of approximately 10 µA and within the range of 200 mV. The threshold level is approximately 0.1 V.

**Measurement Ranges and Accuracies (continued)**

The range below can be used for MXLOGGER (optional software) or API.

Input	Type	Rated measurement range	Measurement accuracy integral time 16.67 ms or more	Measurement accuracy integral time 1.67 ms	Maximum resolution (1 digit)
DC Voltage	60 mV (high resolution)	0.000 to 60.000 mV	±(0.05% of rdg. + 20 digits)	±(0.1% of rdg. + 100 digits)	1 μV
	1 V	-1.0000 to 1.0000 V	±(0.05% of rdg. + 2 digits)	±(0.1% of rdg. + 10 digits)	100 μV
	6 V (high resolution)	0.0000 to 6.0000 V	±(0.05% of rdg. + 20 digits)	±(0.1% of rdg. + 100 digits)	100 μV
Thermocouple RJC accuracy not included	PLATINEL	0.0 to 1400.0°C	±(0.05% of rdg. + 1°C)	±(0.1% of rdg. + 4°C)	0.1°C
	PR40-20 *1	0.0 to 1900.0°C	±(0.05% of rdg. + 2.5°C) However, 300 to 700°C: ±6°C Less than 300°C: accuracy not guaranteed	±(0.1% of rdg. + 12°C) However, 300 to 700°C: ±25°C Less than 300°C: accuracy not guaranteed	
	NiNiMo	0.0 to 1310.0°C	±(0.05% of rdg. + 0.7°C)	±(0.1% of rdg. + 2.7°C)	
	WRe3-25	0.0 to 2400.0°C	±(0.05% of rdg. + 2°C) However, 0 to 200°C: ±2.5°C 2000°C or more: ±(0.05% of rdg. + 4°C)	±(0.1% of rdg. + 7°C) However, 0 to 200°C: ±12°C 2000°C or more: ±(0.1% of rdg. + 11°C)	
	W/WRe26	0.0 to 2400.0°C	±(0.05% of rdg. + 2°C) However, 100 to 300°C: ±4°C Less than 100°C: accuracy not guaranteed	±(0.1% of rdg. + 8.5°C) However, 100 to 300°C: ±12°C Less than 100°C: accuracy not guaranteed	
	Type-N (AWG14)	0.0 to 1300.0°C	±(0.05% of rdg. + 0.7°C)	±(0.1% of rdg. + 3.5°C)	
3-wire RTD (Measurement current 1 mA)	Cu10 at 20°C alpha=0.00392	-200.0 to 300.0°C	±(0.1% of rdg. + 2°C)	±(0.2% of rdg. + 5°C)	0.1°C
	Cu10 at 20°C alpha=0.00393	-200.0 to 300.0°C			
	Cu25 at 0°C alpha=0.00425	-200.0 to 300.0°C	±(0.1% of rdg. + 0.5°C)	±(0.2% of rdg. + 2°C)	0.1°C
	Cu53 at 0°C alpha=0.00426035	-50.0 to 150.0°C	±(0.05% of rdg. + 0.3°C)	±(0.1% of rdg. + 1.5°C)	0.1°C
	Cu100 at 0°C alpha=0.00425	-50.0 to 150.0°C			
	Pt25(JPt100×1/4)	-200.0 to 550.0°C	±(0.1% of rdg. + 0.5°C)	±(0.2% of rdg. + 2°C)	0.1°C
	Cu10 GE *2 (high resolution)	-200.0 to 300.0°C	±(0.1% of rdg. + 2°C)	±(0.2% of rdg. + 5°C)	0.1°C
	Cu10 L&N *2 (high resolution)	-200.0 to 300.0°C			
	Cu10 WEED *2 (high resolution)	-200.0 to 300.0°C			
	Cu10 BAILEY *2 (high resolution)	-200.0 to 300.0°C			

\*1 PR40-20: PtRh20%-PtRh40% (John Matthey Plc)

T09.EPS

\*2 Guaranteed accuracy range Cu10 GE: -84.4 to 170.0°C/Cu10 L&N: -75.0 to 150.0°C/Cu10 WEED: -20.0 to 250.0°C/Cu10 BAILEY: -20.0 to 250.0°C



- Reference junction compensation:  
External/internal switchover can be performed for each channel.  
The Remote RJC function is available.
- Reference junction compensation accuracy:  
During the measurement of 0°C or more and during the input terminal temperature balance  
Type R, S, W:  $\pm 1^\circ\text{C}$   
Type K, J, E, T, N, L, U:  $\pm 0.5^\circ\text{C}$   
PLATINEL, NiNiMo, WRe3-25, W/WRe26, N (AWG14):  $\pm 1^\circ\text{C}$   
Internal reference junction compensation for Type B and PR40-20 is fixed to 0°C.
- Maximum input voltage:  
1 VDC range or less, thermocouple, RTD, DI (contact):  $\pm 10$  VDC  
Other measurement ranges:  $\pm 120$  VDC
- Normal mode voltage:  
DCV, TC, DI (level): 1.2 times of the rated range or less (50/60 Hz, peak values including signals)  
RTD 100  $\Omega$  system: 50 mV peak  
RTD 10, 25, 50  $\Omega$  systems: 10 mV peak
- Normal mode rejection ratio (NMRR):  
40 dB or more when the integral time is 16.67 ms or more (50/60 Hz  $\pm 0.1\%$ )  
50/60 Hz is not rejected when the integral time is 1.67 ms.
- Common mode voltage:  
600 VACrms (50/60 Hz), reinforced (double) insulation
- Common mode rejection ratio (CMRR):  
120 dB or more when the integral time is 16.67 ms or more  
80 dB or more when the integral time is 1.67 ms  
(50/60 Hz  $\pm 0.1\%$ , 500  $\Omega$  imbalance, between the minus measurement terminal and ground)
- Common mode voltage between channels:  
120 VACrms (50/60 Hz)
- Noise rejection:  
Rejection by an integrating A/D and the use of low pass filters
- Input resistance:  
10 M $\Omega$  or more for the DC voltage of 1 V range or less and also for the thermocouple range  
Approximately 1 M $\Omega$  if the DC voltage is in the 2 V range or more
- Insulation resistance:  
20 M $\Omega$  or more between the input and ground (500 VDC)
- Input bias current:  
10 nA or less (except when burn-out has been set)
- Withstand voltage:  
1000 VACrms (50/60 Hz) between input terminals, one minute  
3700 VACrms (50/60 Hz) between an input terminal and ground, one minute
- Input signal source resistance:  
2 k $\Omega$  or less for DC voltage and thermocouple  
10  $\Omega$  or less per cable for RTD 50  $\Omega$  or 100  $\Omega$  systems  
1  $\Omega$  or less per cable for RTD 10  $\Omega$  or 25  $\Omega$  systems
- Thermocouple burn-out:  
Checking of the burn-out at a detection cycle specified for each measurement interval, the up/down setting possible, 2 k $\Omega$  or less being normal, 200 k $\Omega$  or more being disconnected. Detection current shall be approximately 10  $\mu\text{A}$ . Detection time shall be approximately 2 ms. Parallel capacity shall be 0.01  $\mu\text{F}$  or less.
- Parallel capacity during RTD: 0.01  $\mu\text{F}$  or less
- Power consumption: Approximately 1.2 W
- External dimension: Approximately 57  $\times$  131  $\times$  151 mm (including the terminal cover)
- Weight: Approximately 0.5 kg
- Terminal type: Clamp terminal. The plate with clamp terminals can be attached/detached.
- Applicable cable size: 0.14-1.5 mm<sup>2</sup> (AWG26-16)

**Influence of operating conditions (applicable if the integral time is 16.67 ms or more)**

Warm-up time: 30 minutes or more after the power supply is turned on.

Influence of ambient temperature:

Influence on a change in ambient temperature of 10°C is within  $\pm(0.05\%$  of rdg. + 0.05% of range).

However, Cu10  $\Omega$ :  $\pm(0.2\%$  of range + 1 digit)

Influence of power supply fluctuations:

Specifications of accuracy are satisfied at AC power 90-132 V or 180-250 V.

Influence of external magnetic fields:

Fluctuations of external magnetic fields of alternate current (50/60 Hz) 400 A/m is  $\pm(0.1\%$  of rdg. + 10 digits) or less.

Influence of signal source resistance:

Influences on fluctuations of signal source resistance (1 k $\Omega$ ) of voltage and thermocouple are:

Voltage: 1 V range or less

$\pm 10 \mu\text{V}$  or less

2 V range or more

$\pm 0.15\%$  of rdg. or less

Thermocouple:  $\pm 10 \mu\text{V}$  or less

RTD: Fluctuation (one common resistance value for three cables) on a change of 10  $\Omega$  per cable for 100  $\Omega$  systems is  $\pm 0.1^\circ\text{C}$  or less ( $\pm 1.0^\circ\text{C}$  or less for other systems).

Fluctuation on the difference of 40 m $\Omega$  in resistance values among conductors (maximum difference among three cables) shall be approximately 0.1°C (for Pt100).

Influence of attitude:

Basically, the system shall be used in a horizontal position with its legs extended downward.

Influence of vibrations:

Fluctuations when sine wave vibrations in the frequency of 10-60 Hz and at an acceleration of 0.2 m/s<sup>2</sup> are applied for two hours respectively in three axis directions shall be  $\pm(0.1\%$  of rdg. + 1 digit) or less.

• Six-Channel Medium-Speed 4-Wire RTD and Resistance Input Module (MX110-V4R-M06)

Style number: S2

Types of measurement: DC voltage, 4-wire RTD, 4-wire resistance, DI (non-voltage contact, LEVEL (5 V logic))

Number of measurement points: 6 (scanning of 6 channels with one A/D)

Input method: Floating unbalanced input, isolation between channels

A/D resolution:  $\pm 20000/\pm 6000$  (16-bit A/D is used)

Measurement interval and A/D integral time: A/D integral time is determined by measurement interval.

Measurement interval	Integral time	Noise rejection /remarks
100 ms	1.67 ms <sup>(*1)</sup>	600 Hz and its integer multiples
200 ms		
500 ms	16.67 ms	60 Hz and its integer multiples
	20 ms	50 Hz and its integer multiples
	Auto	Power supply frequency is automatically detected and is set to 16.67/20 ms
1 s	36.67 ms	50/60 Hz and the respective integer multiples
2 s	100 ms	10 Hz and its integer multiples
5 s	200 ms	Fc = 5 Hz low pass filter
10, 20, 30, 60 s		

(\*1) If resistance measurements are taken at an integral time of 1.67 ms, the measured values may be susceptible to inaccuracies due to power supply frequency noise. If this is the case, set the integral time to 16.67 ms or longer (for a power supply frequency of 60 Hz), or 20 ms or longer (for a power supply frequency of 50 Hz). On this module, the power supply frequency noise can be rejected by selecting a measurement interval of 500ms or more. (on DAQMASTER, the integral time is automatically set when selecting the measurement interval.)

**Measurement Ranges and Accuracies**

The accuracy applies to standard operating conditions: ambient temp: 23±2°C, ambient humidity: 55±10% RH, supply voltage: 90 to 250 VAC, power frequency: 50/60 Hz ± 1%, warm-up time: at least 30 minutes, without adverse conditions such as vibrations.

Input	Type	Rated measurement range	Measurement accuracy integral time 16.67 ms or more	Measurement accuracy integral time 1.67 ms	Maximum resolution (1 digit)
DC voltage	20 mV	-20.000 to 20.000 mV	±(0.05% of rdg. + 5 digits)	±(0.1% of rdg. + 25 digits)	1 μV
	60 mV	-60.00 to 60.00 mV	±(0.05% of rdg. + 2 digits)		10 μV
	200 mV	-200.00 to 200.00 mV		±(0.05% of rdg. + 5 digits)	±(0.1% of rdg. + 10 digits)
	2 V	-2.0000 to 2.0000 V			
	6 V	-6.000 to 6.000 V			
	20 V	-20.000 to 20.000 V			
	100 V	-100.00 to 100.00 V	±(0.05% of rdg. + 2 digits)		
				10 mV	
DI	Level	V <sub>th</sub> = 2.4 V	Threshold level accuracy ±0.1 V		
	Non-voltage contact	1 kΩ or less: ON, 100 kΩ or more: OFF (parallel capacity is 0.01 μF or less) *1			
4-wire RTD (Measurement current 1 mA)	Pt100 *2	-200.0 to 600.0°C	±(0.05% of rdg. + 0.3°C)	±(0.1% of rdg. + 1.5°C)	0.1°C
	JPt100 *2	-200.0 to 550.0°C			
	Pt100 (high resolution)	-140.00 to 150.00°C			
	JPt100 (high resolution)	-140.00 to 150.00°C			
	Ni100 SAMA *3	-200.0 to 250.0°C			
	Ni100 DIN *3	-60.0 to 180.0°C			
	Ni120 *4	-70.0 to 200.0°C			
	Pt50 *2	-200.0 to 550.0°C			
	Cu10 GE *5	-200.0 to 300.0°C	±(0.1% of rdg. + 2°C)	±(0.2% of rdg. + 5°C)	0.1°C
	Cu10 L&N *5	-200.0 to 300.0°C			
	Cu10 WEED *5	-200.0 to 300.0°C			
	Cu10 BAILEY *5	-200.0 to 300.0°C			
	J263B	0.0 to 300.0 K	±(0.05% of rdg. + 0.3 K)	±(0.1% of rdg. + 1.5 K)	0.1 K
4-wire RTD (Measurement current 0.25mA)	Pt500 *6	-200.0 to 600.0°C	±(0.05% of rdg. + 0.3°C)	±(0.1% of rdg. + 1.5°C)	0.1°C
	Pt1000 *6	-200.0 to 600.0°C			
4-wire resistance	20 Ω (measurement current: 1 mA)	0.000 to 20.000 Ω	±(0.05% of rdg. + 7 digits)	±(0.1% of rdg. + 25 digits)	0.001 Ω
	200 Ω (measurement current: 1 mA)	0.00 to 200.00 Ω	±(0.05% of rdg. + 3 digits)	±(0.1% of rdg. + 15 digits)	0.01 Ω
	2 kΩ (measurement current: 0.25 mA)	0.0 to 2000.0 Ω	±(0.05% of rdg. + 3 digits)	±(0.1% of rdg. + 10 digits)	0.1 Ω

\*1 To be determined at the measurement current of approximately 10 μA and within the range of 200 mV. The threshold level is approximately 0.1 V.

\*2 Pt50: JIS C 1604-1981, JIS C 1606-1986/Pt100: JIS C 1604-1989, JIS C 1606-1989, IEC 751, DIN IEC 751/JPt100: JIS C 1604-1981, JIS C 1606-1989

\*3 SAMA/DIN

\*4 McGRAW EDISON COMPANY

\*5 Guaranteed accuracy range Cu10 GE: -84.4 to 170.0°C/Cu10 L&N: -75.0 to 150.0°C/Cu10 WEED: -20.0 to 250.0°C/Cu10 BAILEY: -20.0 to 250.0°C

\*6 The Pt500 resistance table is Pt100 × 5, and the Pt1000 resistance table is Pt100 × 10.

T11.EPS

**Measurement Ranges and Accuracies (continued)**

The range below can be used for MXLOGGER (optional software) or API.

Input	Type	Rated measurement range	Measurement accuracy integral time 16.67 ms or more	Measurement accuracy integral time 1.67 ms	Maximum resolution (1 digit)
DC voltage	60 mV (high resolution)	0.000 to 60.000 mV	±(0.05% of rdg. + 20 digits)	±(0.1% of rdg. + 100 digits)	1 μV
	1 V	-1.0000 to 1.0000 V	±(0.05% of rdg. + 2 digits)	±(0.1% of rdg. + 10 digits)	100 μV
	6 V (high resolution)	0.0000 to 6.0000 V	±(0.05% of rdg. + 20 digits)	±(0.1% of rdg. + 100 digits)	100 μV
4-wire RTD (Measurement current 1 mA)	Cu10 at 20°C alpha=0.00392	-200.0 to 300.0°C	±(0.1% of rdg. + 2°C)	±(0.2% of rdg. + 5°C)	0.1°C
	Cu10 at 20°C alpha=0.00393	-200.0 to 300.0°C			
	Cu25 at 0°C alpha=0.00425	-200.0 to 300.0°C	±(0.1% of rdg. + 0.5°C)	±(0.2% of rdg. + 2°C)	0.1°C
	Cu53 at 0°C alpha=0.00426035	-50.0 to 150.0°C	±(0.05% of rdg. + 0.3°C)	±(0.1% of rdg. + 1.5°C)	0.1°C
	Cu100 at 0°C alpha=0.00425	-50.0 to 150.0°C			
	Pt25(JPt100×1/4)	-200.0 to 550.0°C	±(0.1% of rdg. + 0.5°C)	±(0.2% of rdg. + 2°C)	0.1°C
	Cu10 GE *1 (high resolution)	-200.0 to 300.0°C	±(0.1% of rdg. + 2°C)	±(0.2% of rdg. + 5°C)	0.1°C
	Cu10 L&N *1 (high resolution)	-200.0 to 300.0°C			
	Cu10 WEED *1 (high resolution)	-200.0 to 300.0°C			
	Cu10 BAILEY *1 (high resolution)	-200.0 to 300.0°C			

T12.EPS

\*1 Guaranteed accuracy range Cu10 GE: -84.4 to 170.0°C/Cu10 L&N: -75.0 to 150.0°C/Cu10 WEED: -20.0 to 250.0°C/Cu10 BAILEY: -20.0 to 250.0°C

Maximum input voltage: 1 VDC range or less/RTD/resistance/DI (contact): ±10 VDC (continuous)

Other measurement ranges: ±120 VDC (continuous)

Normal mode voltage:

VDC, DI (LEVEL): 1.2 times the rated range or less (50/60 Hz, peak values including signals)

2 kΩ resistance, RTD 100/500/1000 Ω systems: 50 mV peak

200 Ω resistance, RTD 10/25/50 Ω systems: 10 mV peak

20 Ω resistance: 4 mV peak

Normal-mode rejection ratio (NMRR):

40 dB or more (50/60 Hz ±0.1%) when the integral time is 16.67 ms or more.

50/60 Hz is not rejected when the integral time is 1.67 ms.

Common mode voltage: 600 VACrms (50/60 Hz), reinforced (double) insulation

Common-mode rejection ratio (CMRR):

120 dB or more when the integral time is 16.67 ms or more. 80 dB or more when the integral time is 1.67 ms.

50/60 Hz ±0.1%, 500 Ω imbalance (for voltage), between the minus measurement terminal and ground, (In the RTD and resistance ranges, CMRR is calculated by the voltage conversion values while the measured current is applied).

Common mode voltage between channels: 120 VACrms (50/60 Hz) for DCV/DI

50 VACrms (50/60 Hz) for RTD/resistance

Noise rejection: Rejection by the integrating A/D and the use of low pass filters.

Input resistance: 10 MΩ or more at the 1 VDC range or lower.

Approximately 1 MΩ at the 2 VDC range or higher.

Insulation resistance: 20 MΩ or more between an input terminal and ground (500 VDC)

Input bias current: 10 nA or less

Withstanding voltage:

Between input terminals (DCV or DI range), 1000 VACrms (50/60 Hz) for one minute

Between input terminals (RTD or resistance range), 620 VACrms (50/60 Hz) for one minute

Between an input terminal and ground, 3700 VACrms (50/60 Hz) for one minute

Input signal source resistance:  
2 k $\Omega$  or less for DCV range  
10  $\Omega$  or less per cable for the resistance and RTD ranges (common for all ranges)

Allowable parallel capacity: 0.01  $\mu$ F or less (when using the resistance or RTD range)

Power consumption: Approximately 1.2 W

External dimension: Approximately 57 × 131 × 151 mm (including the terminal cover)

Weight: Approximately 0.5 kg

Terminal type: Clamp terminal. The plate with clamp terminals can be attached/detached.

Applicable cable size: 0.14-1.5 mm<sup>2</sup> (AWG26-16)

**Influence of operating conditions (applicable if the integral time is 16.67 ms or more)**

Warm-up time: 30 minutes or more after the power supply is turned on.

Influence of ambient temperature: Influence on a change in ambient temperature of 10°C is within  $\pm(0.05\%$  of rdg. + 0.05% of range). However, Cu10  $\Omega$ :  $\pm(0.2\%$  of range + 1 digit)

Influence of power supply fluctuations: Specifications of accuracy are satisfied at AC power 90-132 V or 180-250 V.

Influence of external magnetic fields: Fluctuations of external magnetic fields of alternate current (50/60 Hz) 400 A/m is  $\pm(0.1\%$  of rdg. + 10 digits) or less

Influence of signal source resistance:  
Influences on fluctuations of signal source resistance (1 k $\Omega$ ) of voltage are:  
1 V range or lower:  $\pm 10$   $\mu$ V or less  
2 V range or more:  $\pm 0.15\%$  of rdg. or less  
Fluctuations on a change of 10  $\Omega$  per resistance temperature detector cable are:  
1000  $\Omega$ , or 100  $\Omega$  systems:  $\pm 0.1^\circ$ C or less  
Other systems:  $\pm 1.0^\circ$ C or less  
Fluctuations on a change of 10  $\Omega$  per resistance cable are within  $\pm 1$  digit.

Influence of attitude:  
Basically, the system shall be used in a horizontal position with its legs extended downward.

Influence of vibration:  
Fluctuations when sine wave vibrations in the frequency of 10-60 Hz and at an acceleration of 0.2 m/s<sup>2</sup> are applied for two hours respectively in three axis directions shall be  $\pm(0.1\%$  of rdg. + 1 digit) or less.



• Four-Channel Medium-Speed Strain Input Module (MX112-xxx-M04)

Style number: S2

Types of measurement: Strain gauge or strain gauge sensor (static strain)

Number of measurement points: 4 (scanning of 4 channels with one A/D)

Input method: Floating balanced input

A/D resolution: ±20000 (16-bit A/D is used), except for an integral time of 1.67 ms

Measurement interval and A/D integral time: A/D integral time is determined by measurement interval.

Measurement interval	Integral time	Noise rejection /remarks
100 ms	1.67 ms <sup>(*)</sup>	600 Hz and its integer multiples
200 ms	16.67 ms	60 Hz and its integer multiples
	20 ms	50 Hz and its integer multiples
	Auto	Power supply frequency is automatically detected and is set to 16.67/20 ms
500 ms	36.67 ms	50/60 Hz and the respective integer multiples
1 s	100 ms	10 Hz and its integer multiples
2 s	200 ms	Fc = 5 Hz low pass filter
5, 10, 20, 30, 60 s		

T13.EPS

(\*) If strain measurements are taken at an integral time of 1.67 ms, the measured values may be susceptible to inaccuracies due to power supply frequency noise. If this is the case, set the integral time to 16.67 ms or longer (for a power supply frequency of 60 Hz), or 20 ms or longer (for a power supply frequency of 50 Hz). On this module, the power supply frequency noise can be rejected by selecting a measurement interval of 200 ms or more. (on DAQMASTER, the integral time is automatically set when selecting the measurement interval.)

Gauge connection method:

Single-gauge (2 or 3 wire), opposed-side two-gauge, adjacent-side two-gauge or four-gauge.

In the case of -B12 and -B35, set the connection method using the DIP switch on the module. -B12 and -B35 allow DIP switch setting by channel.

Applicable gauge resistance:

100 to 1000 Ω.

Built-in resistance of 120 Ω for -B12, and 350 Ω for -B35

Bridge voltage: 2 VDC fixed (accurate to ±5 %)

Applicable gauge factor: 2.0 fixed, gauge factor correction possible with scaling function

Balance adjustment: Automatic (digital computation method)

Balance adjustment range: ±10,000 μ strain (for single-gauge method)

Balance adjustment accuracy: Less than or equal to the measurement accuracy

Measurement ranges and accuracies (single-gauge method conversion, other gauge methods use conversion by scaling):

The accuracy applies to standard operating conditions: ambient temp: 23±2°C, ambient humidity: 55±10% RH, supply voltage: 90 to 250 VAC, power frequency: 50/60 Hz ± 1%, warm-up time: at least 30 minutes, without adverse conditions such as vibrations.

Measurement range	Measuring range	Integral time 16.67 ms or more		Integral time 16.67 ms	
		Measurement accuracy	Resolution	Measurement accuracy	Resolution
2000 μ strain	± 2000 μ strain	± 0.5% of range	0.1 μ strain	2% of range	1 μ strain
20000 μ strain	± 20000 μ strain	± 0.3% of range	1 μ strain	1% of range	2 μ strain
200000 μ strain	± 200000 μ strain	± 0.3% of range	10 μ strain	1% of range	10 μ strain

T14.EPS

Bridge resistance accuracy (-B12, -B35): ±0.01% ±5 ppm/°C

Input resistance: 1 MΩ or more

Allowable wiring resistance: 100 Ω or less

Influence of wiring resistance:

For -B12 and -B35, the wiring resistance component is not corrected.

Depends on the gauge resistance.

For -NDI, 50 ppm of rdg./Ω (when using remote sense wires)

Temperature coefficient: ±100 ppm of range/°C

Allowable input voltage:  $\pm 10$  VDC (between H-L) continuous

Normal-mode rejection ratio (NMRR):

40 dB or more (50/60 Hz  $\pm 0.1\%$ ) when the integral time is 16.67 ms or more.

50/60 Hz is not rejected when the integral time is 1.67 ms.

(voltage conversion value given a bridge voltage of 2 V).

Common mode voltage:

-B12, -B35: Between channels: 30 VACrms (50/60 Hz)

Between an input terminal and ground: 250 VACrms (50/60 Hz)

-NDI: Between channels: 30 VACrms (50/60 Hz)

Between an input terminal and ground: 30 VACrms (50/60 Hz)

(the connector shell is connected to earth potential.)

Common-mode rejection ratio (CMRR), (-NDI is not applicable.):

120 dB or more when the integral time is 16.67 ms or more. (50/60 Hz  $\pm 0.1\%$ )

80 dB or more when the integral time is 1.67 ms. (50/60 Hz  $\pm 0.1\%$ )

(voltage conversion value given a bridge voltage of 2 V)

Influence of external magnetic fields: Fluctuations of external magnetic fields of alternate current (50/60 Hz) 400 A/m is

$\pm 2\%$  of range or less (measurement interval of 200 ms or more).

Insulation resistance (-NDI is not applicable.):

Between an input terminal and ground, 20 M $\Omega$  or more (500 VDC)

Withstanding voltage (-NDI is not applicable.):

Between an input terminal and ground, 2300 VACrms (50/60 Hz) for one minute

Between channels, 30 VACrms or less

Terminal type:

-B12, -B35: Clamp terminal (the plate with clamp terminals can be attached/detached.)

-NDI: NDIS connector

Applicable cable size (-B12, -B35): 0.14-1.5 mm<sup>2</sup> (AWG26-16)

Power consumption: Approximately 3 W

External dimension: Approximately 57  $\times$  131  $\times$  151 mm (including the terminal cover)

Weight: Approximately 0.5 kg

Calculations related to strain measurement (performed on the main module):

Initial balance: The initial balance value is measured and set as the 0 point.

Initialization of the initial balance value: Returns the initial balance value to 0.

Reloading of the initial balance value: Reloads the saved initial balance value.

When using Yokogawa's dedicated software (MX100 Standard Software or MXLOGGER), the initial balance value is stored in the PC software project file. Reloading is performed by reading the project file.

### • Ten-Channel High-Speed 5 V Digital Input Module (MX115-D05-H10)

Style number: S1

Input type: Non-voltage contact, level (5 V logic), open collector

Number of channels: 10

Input format: Pull-up at approximately 5 V/approximately 5 k $\Omega$ . No isolation between channels

Measurement interval: 10/50/100/200/500 ms, 1/2/5/10/20/30/60 s

Filter: Measurement interval of 5 s or less: Uses the widest ON/OFF width during the detection period (approximately 75% to 90% of the measurement interval).

Measurement interval of 5 s or more: Uses the widest ON/OFF width during approximately 4.5 s

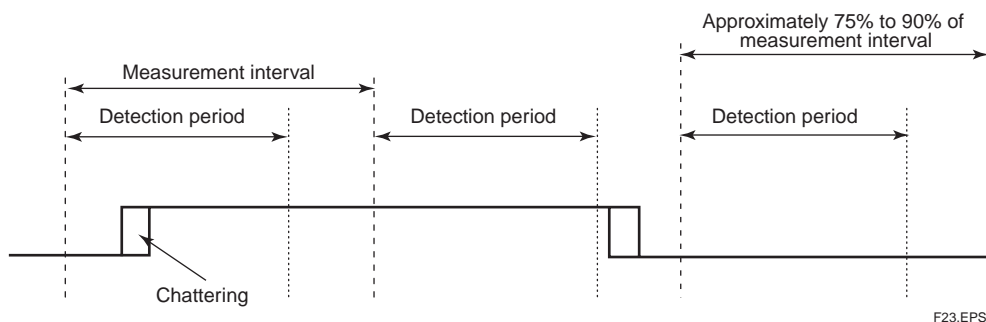

If a measurement interval is set to four times or more of the chattering continuation time, measurement can be performed without being influenced by chattering. (Reference information: The chattering of the general relays is approximately 20 ms.)

Minimum detection pulse width: two times or more of a measurement interval

Input threshold level: Non-voltage contact, open collector: "On" for 100  $\Omega$  or less, "Off" for 100 k $\Omega$  or more

Level (5 V logic): "Off" for 1 V or less, "On" for 3 V or more

Hysteresis width: Approximately 0.1 V

Contact, rated transistor:

Rated contact with 15 VDC or more and 30 mA or more

Rated transistor with  $V_{ce} > 15$  Vdc and  $I_c > 30$  mA

Maximum input voltage: 10 VDC

Common mode voltage: 250 VACrms (50/60 Hz) between an input terminal and ground

Insulation resistance: 20 M $\Omega$  or more (500 VDC) between an input terminal and ground

Withstand voltage: 2300 VACrms (50/60 Hz) between an input terminal and ground, one minute

Power consumption: Approximately 1.5 W

External dimension: Approximately 57  $\times$  131  $\times$  151 mm (including the terminal cover)

Weight: Approximately 0.5 kg

Terminal type: Clamp terminal. The plate with clamp terminals can be attached/detached.

Applicable cable size: 0.14-1.5 mm<sup>2</sup> (AWG26-16)

• Ten-Channel High-Speed 24 V Digital Input Module (MX115-D24-H10)

Style number: S2

Input type: Level (24 V logic), No isolation between channels

Number of channels: 10

Measurement interval: 10/ 50/100/200/500 ms, 1/2/5/10/20/30/60 s

Filter: Measurement interval of 5 s or less: Uses the widest ON/OFF width during the detection period (approximately 75% to 90% of the measurement interval).

Measurement interval of 5 s or more: Uses the widest ON/OFF width during approximately 4.5 s

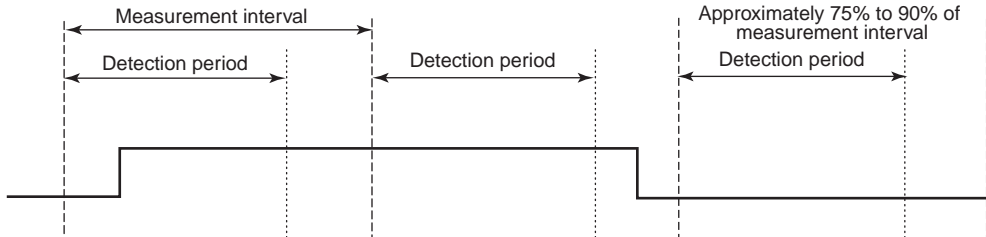

F24.EPS

Input resistance: Approximately 200 kΩ (between + and – terminals)

Maximum input voltage: 50 VDC

Minimum detection pulse width: two times the measurement interval or more

Input threshold level: "Off" for 6 V or less, "ON" for 16 V or more

Hysteresis width: Approximately 1.5 V

Common mode voltage: 250 VACrms (50/60 Hz) between an input terminal and ground

Insulation resistance: 20 MΩ or more between an input terminal and ground (500 VDC)

Withstand voltage: 2300 VACrms (50/60 Hz) between an input terminal and ground, one minute

Power consumption: Approximately 1.5 W

External dimension: Approximately 57 × 131 × 151 mm (including the terminal cover)

Weight: Approximately 0.5 kg

Terminal type: Clamp terminal. The plate with clamp terminals can be attached/detached.

Applicable cable size: 0.14-1.5 mm<sup>2</sup> (AWG26-16)

### • Eight-Channel Medium-Speed Analog Output Module (MX120-VAO-M08)

Style number: S2

Number of output points: 8

Output types: DC voltage, DC current (allows mixed voltage and current output)

Output data:

Command output, manual output: Output of set and calculated values, and retransmission of measured values across units are carried out by commands from the PC.

Retransmission output: Scales values measured on input modules in the same unit and outputs them. Output is continuous even when communications are cut as the operation is performed inside the main module.

Other Output:

Output during power cycle:

Outputs from the time the power is turned ON until measurement starts or a command is received.

Previous values (values active at the time the power was last turned OFF), or preset values can be selected for output.

Output during abnormalities (errors):

Outputs when input values for transmission output are erroneous, communications are cut, the CPU is down, or other errors occur. Previous values (values active just prior to the abnormality), or preset values can be selected for output.

Output during  $\pm$  over:

Output occurs at  $\pm 5\%$  of the output setting span when the input values for transmission output are  $\pm$  over. (However, the available output range is  $-11$  V to  $11$  V (voltage) and  $0$  to  $20$  mA (current)).

Note 1) Preset values: Specified values can be set one per channel. However, preset values during power cycle or abnormality (error) are the same.

Note 2) Preset and previous values are stored in the module. The preset and previous values are initialized to  $0$  when the instrument is re-configured.

Output update cycle:  $100$  ms

Rated output range: Voltage:  $-10$  to  $10$  V, current:  $0$  to  $20$  mA, sourcing ( $4$  to  $20$  mA is output at  $1$  to  $5$  V output)

Maximum allowable output range: Voltage:  $-11$  to  $11$  V, current:  $0$  to  $22$  mA

Load resistance: Voltage:  $5$  k $\Omega$  or more, current:  $600$   $\Omega$  or less

Accuracy (at rated output):  $\pm 0.2\%$  of F.S. (F.S. =  $10$  V or  $20$  mA). However, for current output, accuracy is met at  $1$  mA or more. The accuracy applies to standard operating conditions: ambient temp:  $23 \pm 2^\circ\text{C}$ , ambient humidity:  $55 \pm 10\%$  RH, supply voltage:  $90$  to  $250$  VAC, power frequency:  $50/60$  Hz  $\pm 1\%$ , warm-up time: at least  $30$  minutes, without adverse conditions such as vibrations.

Output resolution:  $12$  bit of F.S. or more

The relationship between the output voltage/current value and the internal count value (designed center value)

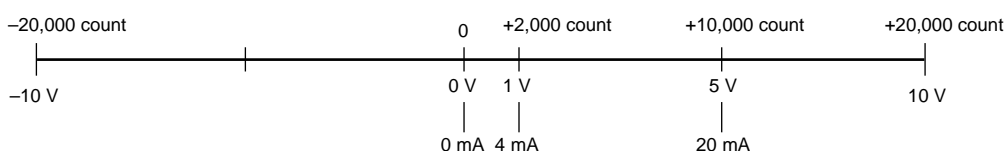

F28.EPS

The setting resolution is as follows.

Yokogawa's dedicated PC software (MX100 Standard Software or MXLOGGER):

$-10.000$  V to  $10.000$  V (1 mV resolution)

$0.000$  mA to  $20.000$  mA (1  $\mu\text{A}$  resolution)

Influence of ambient temperature: Per  $1^\circ\text{C}$ ,  $\pm(50$  ppm of setting +  $50$  ppm of F.S.) or less (F.S. =  $10$  V or  $20$  mA)

External power supply (used for current output):  $24$  V  $\pm 10\%$  and current capacity of  $250$  mA or more.

(Use of external power supplies is not necessary with only voltage output)

Common mode voltage: Between an output terminal and ground,  $250$  VACrms ( $50/60$  Hz)

Insulation resistance: Between an output terminal and ground,  $20$  M $\Omega$  or more ( $500$  VDC)

Between output terminals, non-isolated (minus terminals share common potential)

Withstanding voltage: Between an output terminal and ground,  $2300$  VACrms ( $50/60$  Hz) for one minute

Between output terminals, non-isolated (minus terminals share common potential)

Power consumption: Approximately  $2.5$  W (excluding power consumption of external voltage sources)

External dimension: Approximately  $57 \times 131 \times 151$  mm (including the terminal cover)

Weight: Approximately  $0.5$  kg

Terminal type: Clamp terminal (detachable every 4 channels)

Applicable cable size:  $0.08$ - $2.5$  mm $^2$  (AWG28-12)

Note: The RJC accuracy of an universal input module may be influenced if placed to the left-side of this module.

### • Eight-Channel Medium-Speed PWM Output Module (MX120-PWM-M08)

Style number: S2

Number of output points: 8

Pulse (output) interval: 1 ms to 30 s (1 ms interval setting range, set in 1 ms units per channel)  
10 ms to 300 s (10 ms interval setting range, set in 10 ms units per channel)

Pulse interval accuracy:  $\pm 100$  ppm of setting value

Output update cycle: 100 ms

Update timing: Duty is updated from the falling edge of the next cycle after receiving the update command.

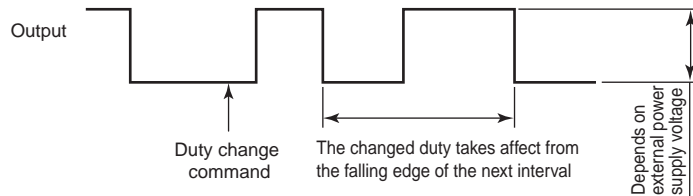

F25.EPS

Duty resolution: 1 ms interval setting range: 1/12000, 10 ms interval setting range: 1/60000

The setting resolution is as follows. However, output is at the hardware resolution above.

Yokogawa's dedicated PC software (MX100 Standard Software or MXLOGGER):

0-100.000% (0.001% resolution)

API/MX100 unit: 0-100% set at 0-100,000 count

Duty accuracy (at load resistance of 100  $\Omega$  or less):

For 1 ms interval setting range,  $\pm 0.017\%$  or  $\pm 2 \mu\text{s}$  whichever is longer.

For 10 ms interval setting range,  $\pm 0.0035\%$  or  $\pm 2 \mu\text{s}$  whichever is longer.

When the load resistance is higher than 100  $\Omega$ , the output Duty may vary from the specification.

Output data:

Command output, manual output: Output of set and calculated values, and retransmission of measured values across units are carried out by commands from the PC.

Retransmission output: Scales values measured on input modules in the same unit and outputs them. Output is continuous even when communications are cut as the operation is performed inside the main module.

Other Output:

Output during power cycle:

Outputs from the time the power is turned ON until measurement starts or a command is received. Previous values (values active at the time the power was last turned OFF), or preset values can be selected for output.

Output during abnormalities (errors):

Outputs when input values for transmission output are erroneous, communications are cut, the CPU is down, or other errors occur. Previous values (values active just prior to the abnormality), or preset values can be selected for output.

Output during  $\pm$  over:

Output occurs at  $\pm 5\%$  of the output setting span when the input values for transmission output are  $\pm$  over. (However, the lower limit is 0% and the upper limit is 100%)

Note 1) Preset values: Specified values can be set one per channel. However, preset values during power cycle or abnormality (error) are the same. The available setting range is 0 to 100%.

Note 2) Preset and previous values are stored in the module. The preset and previous values are initialized to 0 when the instrument is re-configured.

Output format: External power supply sourcing

ON resistance: 2  $\Omega$  or less (when the output current is 200 mA or more)

External power supply: 4 V to 28 V

Output capacity: Max 1 A/ch, however, the total of one module is 4 A or less (approximately 1 A current limit circuit built-in)

Note 1) A current limit circuit of approximately 1 A is built in to the output circuit. Once the current limit circuit turns ON, the limit circuit continues to operate unless the external power supply is turned OFF (holds the output OFF condition). Once the external power supply is turned OFF, check the load condition before restarting it again.

Note 2) This module has a built-in fuse. The built-in fuse protects the instrument from fires or abnormal emission of heat during load shortages or other abnormalities, but does not prevent damage to the internal circuit element.

Common mode voltage: 250 VACrms (50/60 Hz) between an output terminal and ground

Insulation resistance: Between an output terminal and ground, 20 M $\Omega$  or more (500 VDC)

Between output terminals, non-isolated

Withstanding voltage: Between an output terminal and ground, 2300 VACrms (50/60 Hz) for one minute

Between output terminals, non-isolated

Power consumption: Approximately 2.5 W (excluding power consumption of external voltage sources)

External dimension: Approximately 57 × 131 × 151 mm (including the terminal cover)

Weight: Approximately 0.5 kg

Terminal type: Clamp terminal (detachable every 4 channels)

Applicable cable size: 0.08-2.5 mm<sup>2</sup> (AWG28-12)

Note: The RJC accuracy of an universal input module may be influenced if placed to the left-side of this module.

**• Ten-Channel Medium-Speed Digital Output Module (MX125-MKC-M10)**

Style number: S1

Output types: Alarm output, command output (manual output), failure output, error output

Number of output points: 10

Contact mode: "A" contact (SPST)

Output update cycle: output per 100 ms (not synchronize with measurement intervals)

Contact capacity: 250 VDC/0.1 A, 250 VAC/2 A, 30 VDC/2 A (resistance load)

Contact lifespan: Approximately 100,000 times at the rated load.

Approximately 20,000,000 times with no load.

The contact life depends on load and operating conditions.

Common mode voltage: 250 VACrms (50/60 Hz) between an output terminal and ground

Insulation resistance:

20 M $\Omega$  or more (500 VDC) between an output terminal and ground

20 M $\Omega$  or more (500 VDC) between output terminals

Withstand voltage: 2300 VACrms (50/60 Hz) between an output terminal and ground, one minute

2300 VACrms (50/60 Hz) between output terminals, one minute

Power consumption: Approximately 2 W (when all relays are turned on)

External dimension: Approximately 57 × 131 × 151 mm (including the terminal cover)

Weight: Approximately 0.5 kg

Terminal type: Clamp terminal (detachable every 5 channels)

Applicable cable size: 0.08-2.5 mm<sup>2</sup> (AWG28-12)

Others: The excitation/non-excitation switchover and the hold/non-hold switchover are available.



---

## ■ PC software specifications

- **MX100 standard software (attached to the main module of MX100): for connection with a single MX unit**

- **Release number:** R2.01 or later

- **Integrated Monitor (main functions):**

Setting of the basic connection, setting of various conditions (range, measurement interval, computation, tag), monitor display (digital, trend), 32 channels in one group, 10 groups, logging, computation function (60 channels), alarm output, retransmission output, manual digital output, manual analog/PWM output, etc.

- **Viewer (main functions):**

Re-display of saved data files, 32 channels in one group, 50 groups, data synchronization processing, file merge display (limited to files that can be merged), multi-interval supported (If channels with different intervals are assigned to the same group, windows are split (up to four splits) and displayed.), graph, digital display/print, cursor value display, interval arithmetic, alarm display, mark display, alarm/mark search, file information display, tag, tag comment, channel display switchover, data formatting conversion (conversion to ASCII, Excel, or Lotus format), etc.

- **Calibration software (main function): calibration function**

- **Operating environment**

CPU: Intel Pentium II 400 MHz or more (recommended: Pentium III and 1 GHz or more)

Memory: 256 MB or more (recommended: 512 MB or more)

OS: Windows NT 4.0/2000/XP (recommended)

Hard disk capacity: Free space of 50 MB or more (recommended: Hard disk with free space of 1 GB or more that operates at maximum speed)

Communication interface: Ethernet that can be used for Windows (recommended: 100 Base-TX supported)

CD-ROM drive: CD-ROM drive that can be used for Windows (to be used for installation)

Printer: printer that can be used for Windows (to be used for printing)

- **MXLOGGER (optional)**

This is used to connect multiple MX units. Up to 20 units can be connected.

- **Release number:** R2.01 or later

- **Integrated Monitor (main functions):**

Setting of the basic connection, setting of various conditions (range/alarm, measurement interval, computation), project functions (project switchover, copy, deletion), logging, computation function (240 channels, computation across units possible), alarm output, file split save function, retransmission output, manual digital output, manual analog/PWM output, activation of various types of software, display-related settings, 32 channels in one group, 50 groups, monitor displays (trend, digital, meter, alarm), multi-interval supported (If channels with different intervals are assigned to the same group in trend graphs, windows are split (up to four splits) and displayed.), All-channel trend display, temporary suspension, tag, tag comment, channel display switchover, marking function, event processor (automatic conversion, ftp, mail), Automatic start function, etc.

- **Viewer (main functions):**

Re-display of saved data files, data synchronization processing, file merge display (limited to files that can be merged), 32 channels in one group, 50 groups, multi-interval supported (If channels with different intervals are assigned to the same group in trend graphs, windows are split (up to four splits) and displayed.), graph, digital display/print, cursor value display, interval arithmetic, alarm display, mark display, alarm/mark search, file information display, tag, tag comment, channel display switchover, embedding of backup file data, data formatting conversion (conversion to ASCII, Excel, or Lotus format), etc.

- **Monitor Server (main functions):**

Retention of 1,800-point data/channels, connection with DAQLOGGER/AddObserver/AddMulti possible, acquisition of instantaneous values on all channels, etc.

- **DDE server**

- **Operating environment:**

CPU: Intel Pentium III 800 MHz or more (recommended: Pentium 4, 1.6 GHz or more)

Memory: 512 MB or more (recommended: 1 GB or more)

OS: Windows NT 4.0/2000/XP (recommended)

Hard disk capacity: Free space of 100 MB or more (recommended: Hard disk with free space of 2 GB or more that operates at maximum speed)

Communication interface: Ethernet that can be used for Windows (recommended: 100 Base-TX supported)

CD-ROM drive: CD-ROM drive that can be used for Windows (to be used for installation)

Printer: printer that can be used for Windows (to be used for printing)

---

- **API for MX100/DARWIN (optional): a suite of functions for creating PC software**

- **Release number:** R2.01 or later
- Supported models: MX100/DARWIN series
- Supported OS: Windows 98/NT 4.0 SP3 or later/2000/XP
- Communication system: TCP/IP (Ethernet)
- User development environment: MS Visual Studio 6.0 SP5 or later
- Supported language: Visual C, Visual C++, Visual Basic, Visual Basic.NET, C#

**Model Name**

**Main Module**

Model	Suffix Code	Option Code	Description
MX100			Main module (with MX100 Standard Software)
IM Language	-E		With English instruction manual
Power supply voltage	-1		100 VAC-240 VAC
Power supply inlet, power supply cord	D		3-pin power inlet with UL, CSA cable
	F		3-pin power inlet with VDE cable
	R		3-pin power inlet with SAA cable
	Q		3-pin power inlet with BS cable
	H		3-pin power inlet with CCC (China standard) cable
	W		Screw terminal without power cord
Option		/DS	Dual Save function

T15.EPS

**Input/Output Module**

Model	Suffix Code	Option Code	Description
MX110			Analog input module for MX
Input type	-UNV		DCV/TC/DI/3-wire RTD *1
	-V4R		DCV/DI/4-wire RTD/4-wire resistance *1
Measurement interval, number of channels	-H04		4 channels, high speed (shortest measurement interval: 10 ms)
	-M06		6 channels, medium speed (shortest measurement interval: 100 ms) *1
	-M10		10 channels, medium speed (shortest measurement interval: 100 ms) *2
Option		/NC	The plate with clamp terminals is not attached. *2

T16.EPS

- \*1: "-M06" must be specified when "-V4R" is specified.
- "-M06" can not be specified when "-UNV" is specified.
- \*2: "/NC" can be specified only when "-M10" is specified.

Model	Suffix Code	Description
MX112		Strain input module
Input type	-B12	Built-in bridge resistance: 120 Ω
	-B35	Built-in bridge resistance: 350 Ω
	-NDI	For connection to external bridge head and strain gauge type sensor (NDIS connector)
Measurement interval, number of channels	-M04	4 channels, Medium speed (Shortest measurement interval: 100 ms)

T17.EPS

Model	Suffix Code	Option Code	Description
MX115			Digital input module for MX
Input type	-D05		Non-voltage contact, 5 V logic, open collector
	-D24		24 V logic
Measurement interval, number of channels	-H10		10 channels, high speed (shortest measurement interval: 10 ms)
Option		/NC	The plate with clamp terminals is not attached.

T18.EPS

Model	Suffix Code	Description
<b>MX120</b>		Analog output module
Output type	-VAO	Voltage/Current output (allows mixed voltage and current output)
	-PWM	Pulse width modulation output
Measurement interval, number of channels	-M08	8 channels, output update cycle: 100 ms

T19.EPS

Model	Suffix Code	Description
<b>MX125</b>		Digital output module for MX
Output type	-MKC	"A" contact (SPST)
Output update cycle, number of channels	-M10	10 channels, shortest output update cycle: 100 ms

T20.EPS

Model	Suffix Code	Description
<b>MX150</b>		Base plate for MX
Base type	-1	For connection with one main module and one input/output module
	-2	For connection with one main module and two input/output module
	-3	For connection with one main module and three input/output modules
	-4	For connection with one main module and four input/output modules
	-5	For connection with one main module and five input/output modules
	-6	For connection with one main module and six input/output modules

T21.EPS

**Accessories**

Model	Suffix Code	Description
<b>772050</b>		MX100 version up kit
	-01	Upgrade to the most recent style

T22.EPS

Note: The 772050-01 is only available for the standard, non-customized MX100. Also, the /DS option cannot be added with this kit.

Model	Description
<b>772061</b>	Ten-Channel Screw (M4) Terminal Block (RJC included)

T23.EPS

Note: The 772061 model is applicable only to the MX110-UNV-M10 (Ten-Channel Medium-Speed Universal Input Module), the MX115-D05-H10 (Ten-Channel High-Speed 5 V Digital Input Module) or the MX115-D24-H10 (Ten-Channel High-Speed 24 V Digital Input Module).

Model	Suffix Code	Description
<b>772062</b>		Cable for connection between the input module and the screw terminal block
Cable length	-050	50 cm cable
	-100	100 cm cable

T24.EPS

Note: The 772062 model is applicable only between the MX110-UNV-M10 (Ten-Channel Medium-Speed Universal Input Module) and the Screw Terminal Block (772061), between the MX115-D05-H10 (Ten-Channel High-Speed 5 V Digital Input Module) and the Screw Terminal Block (772061) or between the MX115-D24-H10 (Ten-Channel High-Speed 24 V Digital Input Module) and the Screw Terminal Block (772061).

Model	Description
772063	Plate with clamp terminals (RJC included)

T25.EPS

Note: The 772063 model is applicable only to the MX110-UNV-M10 (Ten-Channel Medium-Speed Universal Input Module), the MX115-D05-H10 (Ten-Channel High-Speed 5 V Digital Input Module) or the MX115-D24-H10 (Ten-Channel High-Speed 24 V Digital Input Module).

Model	Description
772064	Clamp terminals

T26.EPS

Note: The 772064 model is applicable only to the MX110-UNV-H04 (Four-Channel High-Speed Universal Input Module).

Model	Description
772065	Clamp terminals

T27.EPS

Note: The 772065 model is applicable only to the MX120-VAO-M08 (Eight-Channel Medium-Speed Analog Output Module), the MX120-PWM-M08 (Eight-Channel Medium-Speed PWM Output Module) or the MX125-MKC-M10 (Ten-Channel Medium-Speed Digital output Module).

Model	Description
772066	Connector cover for base plate

T28.EPS

Model	Description
772067	Plate with clamp terminals

T29.EPS

Note: The 772067 model is applicable only to the MX110-V4R-M06 (Six-Channel Medium-Speed 4-Wire RTD and Resistance Input Module).

Model	Description
772068	Plate with clamp terminals (Built-in bridge resistance of 120 Ω)

T30.EPS

Note: The 772068 is applicable only to the MX112-B12-M04 (Four-Channel Medium Speed Strain Input Module, 120 Ω), or the MX112-B35-M04 (Four-Channel Medium Speed Strain Input Module, 350 Ω).

Model	Description
772069	Plate with clamp terminals (Built-in bridge resistance of 350 Ω)

T31.EPS

Note: The 772069 is applicable only to the MX112-B35-M04 (Four-Channel Medium Speed Strain Input Module, 350 Ω), or the MX112-B12-M04 (Four-Channel Medium Speed Strain Input Module, 120 Ω).

Model	Description
772080	Screw (M3) terminal plate (with RJC)

T34.EPS

Note 1: The 772080 is applicable only to the MX110-UNV-M10 (Ten-Channel Medium Speed Universal Input Module), the MX115-D05-H10 (Ten-Channel High Speed 5 V DI Module), and the MX115-D24-H10 (Ten-Channel High Speed 24 V DI Module).

Note 2: Terminal cover included

Note 3: b terminals for RTD are common (2 terminals)

Description	Model	Specifications
Adapter for CompactFlash card	<b>772090</b>	
CompactFlash card	<b>772091</b>	128 MB *1
CompactFlash card	<b>772092</b>	256 MB *1
CompactFlash card	<b>772093</b>	512 MB *1
CompactFlash card	<b>772094</b>	1 GB *1

\*1: Operating temperature range: -40°C to 85°C

T35.EPS

### Accessories (available separately)

Name	Model (Part No.)	Specifications
Shunt Resistance (for clamp terminals)	438920	250Ω ± 0.1%
	438921	100Ω ± 0.1%
	438922	10Ω ± 0.1%
Shunt Resistance (for screw terminals)	415920	250Ω ± 0.1%
	415921	100Ω ± 0.1%
	415922	10Ω ± 0.1%

T32.EPS

### Application Software

Model	Description
<b>MX180</b>	MX100 Standard Software (For connection with one MX unit)
<b>WX103/CD1</b>	MXLOGGER (For connection with multiple MX units. Up to 20 units)
<b>MX190</b>	API for MX100/DARWIN (Suite of functions for creating programs)

T33.EPS

External Drawing

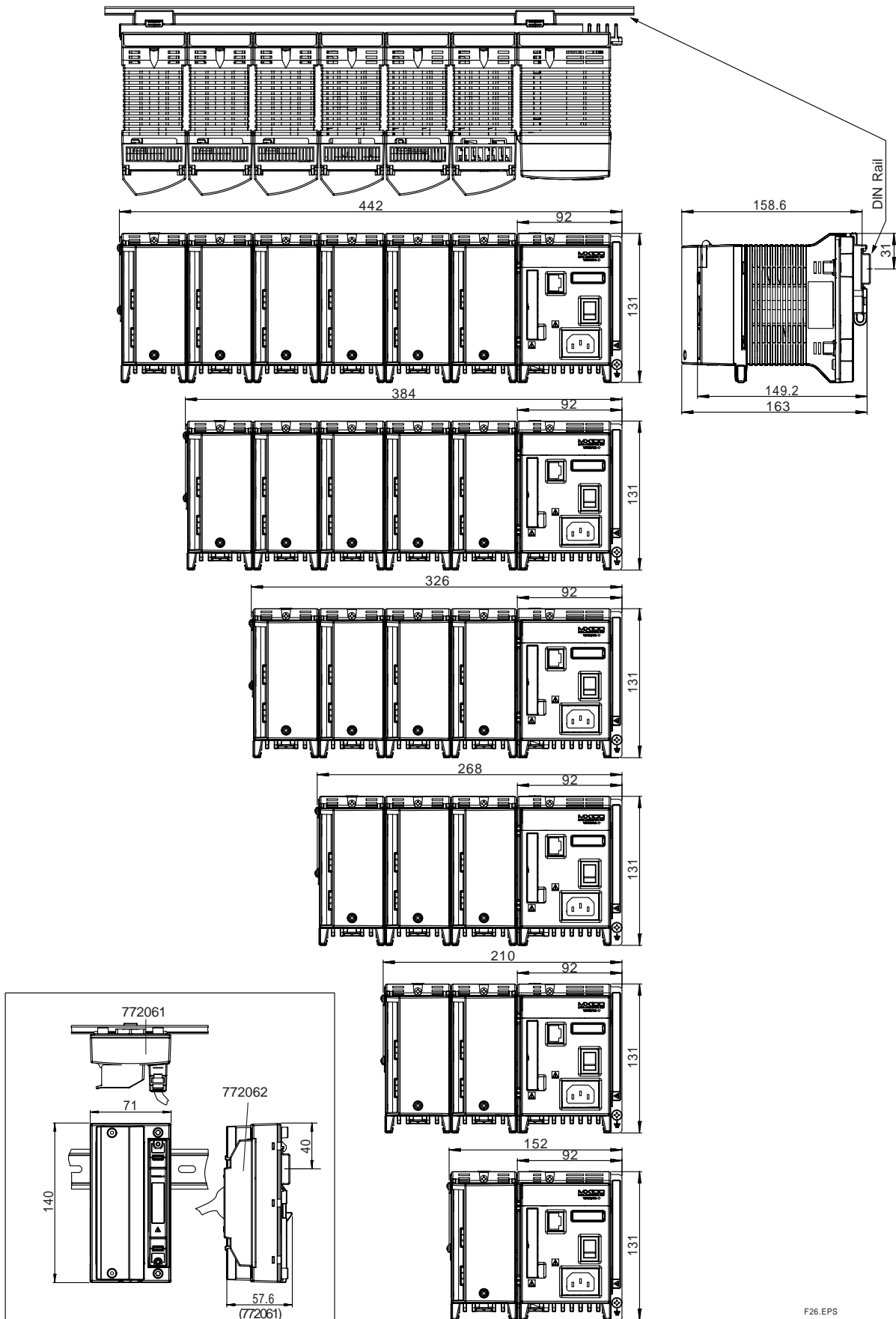

F26.EPS

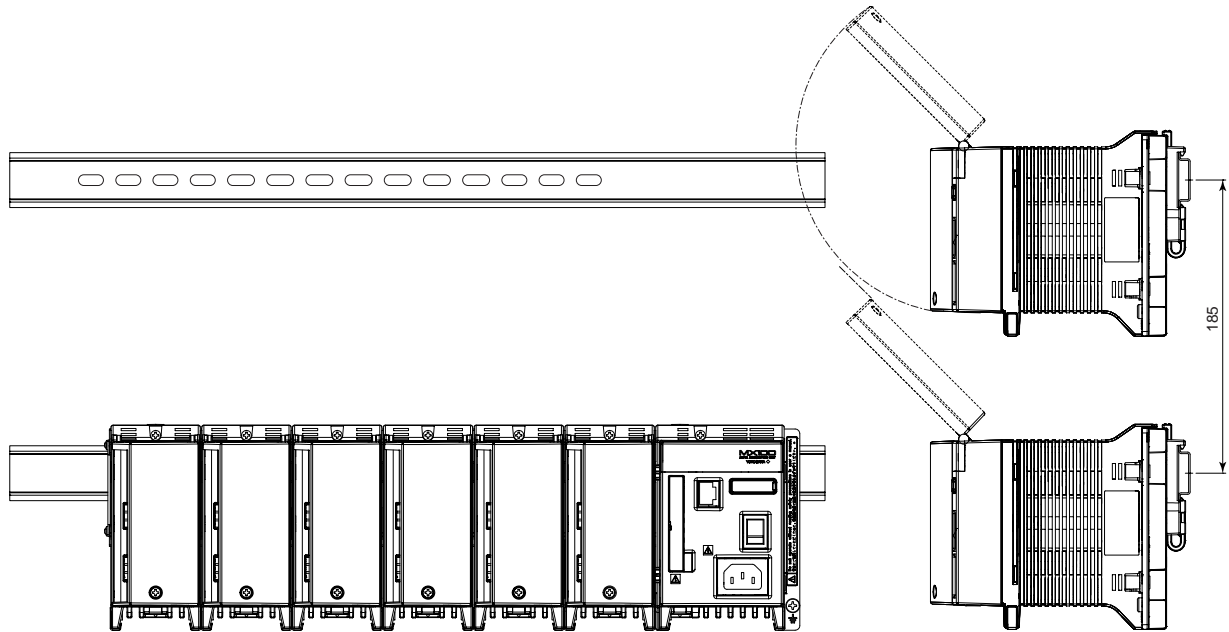

F27.EPS

Dimension for installation in upper and lower directions using the DIN rail.

**Caution when mounting the DIN rail:**

Be sure to fix the DIN rail (such as by screws) at three or more points including both ends of the equipment and the center. If it is fixed at two points or less, the equipment may bend.

DAQMASTER is a registered trademark of Yokogawa Electric Corporation.  
TCP/IP software of this product and documents on TCP/IP software were developed/created by Yokogawa Electric Corporation on the basis of BSD Networking Software (Release 1) licensed from University of California.  
Microsoft, MS, Windows, and Excel are registered trademarks of Microsoft Corporation in the United States.  
Lotus and 1-2-3 are registered trademarks of Lotus Development Corporation.  
MMX and Pentium are registered trademarks of Intel Corporation in the United States.  
Ethernet is a registered trademark of XEROX Corporation.  
All other company and product names mentioned here are trademarks or registered trademarks of their respective companies.